

**MP/MR Series
VDMA 24562
ISO 6431**



PNEUMATIC CYLINDERS

An **IMC** Company

MIDLAND
PNEUMATIC

General **Page numbers**

General description and application benefits	3
Functional symbols	3
Model code	4
Preferred models - Basic cylinders	4
Cylinder sizing	5
Installation dimensions - Basic profile and round barrel cylinders	6

Cylinder options **Page numbers**

Double acting through rod cylinders	7
Double acting rear connection cylinders	8
Double acting front connection cylinders	8
Double acting high temperature cylinders	9
Double acting braking cylinders	10 - 11
Double acting gaitered cylinders	12
Double acting positioner controlled cylinders	13

Mountings **Page numbers**

Front flange (MF1) and rear flange (MF2)	14
Feet (MS2)	14
Rear clevis (MP2)	14
Rear eye (MP4)	15
Rear hinge mount (MP2 + MP4 + Pivot pin)	15
Rear 90° hinge (MP2 + 90° Bracket + Pivot pin)	15
Centre trunnion (MT4)	16

Accessories **Page numbers**

Fork end with lockable pivot pin	17
Fork end with pivot pin	17
Rod spherical bearing	17
Pivot pin	17
Piston rod locknut	17

Magnetic sensors **Page numbers**

Reed switch	18
-------------	----



VDMA/ISO POWER CYLINDERS DOUBLE ACTING

VDMA
ISO
CYLINDERS

32, 40, 50, 63, 80, 100, 125, 160, 200mm bore

General description and benefits

A range of double acting, fully adjustable cushioned metric cylinders to VDMA 24562 and BS ISO 6431 standards.

Profile barrels (MP range) or with conventional round barrels (MR range).

- Simple reliable design.
- Meets International and European standards.
- Clean lines.
- Magnetic piston option.
- Customers required stroke supplied as standard.
- Adjustable air cushioning.
- Lube free.
- Full range of mounting accessories.
- Customised designs available.

Functional symbols

Double acting
Double cushioned

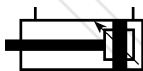

Double acting through rod
Double cushioned



Double acting rear connection twin cylinders
Double cushioned



Double acting front connection twin cylinders
Double cushioned

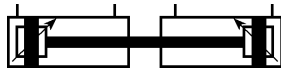

Double acting braking cylinder
Double cushioned



Double acting positioner controlled cylinder
Double cushioned

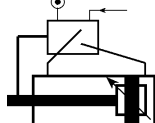

Operating fluids

Compressed air

Filtered and lubricated or non lubricated up to 12 bar (174 psi).

ISO VG32 or ISO VG37 mineral oil is recommended for use in lubricated systems.

Technical data

Operating pressure

Standard
0.5 to 10 bar (7.25 to 145 psi)

Maximum
0.5 to 12 bar (7.25 to 174 psi)

Ambient operating temperature range

-10°C to +85°C (14°F to 185°F)

Ports

Screwthread 1/8" - 3/4" BSP

Cushioning

Fully adjustable air cushioning at both ends.

Cushioning length

32mm bore cylinders - 19mm
 40mm bore cylinders - 23mm
 50mm bore cylinders - 21mm
 63mm bore cylinders - 23mm
 80mm bore cylinders - 24mm
 100mm bore cylinders - 29mm
 125mm bore cylinders - 36mm
 160mm bore cylinders - 21mm
 200mm bore cylinders - 45mm

Materials of construction

Barrel

Profile tube (MP range).
 Hard anodised aluminium alloy.
 Round tube (MR range)
 Hard anodised aluminium alloy.

End covers

Hard anodised aluminium alloy.

Piston rod

Stainless steel AISI 303

Piston

Aluminium

Tie rods

Stainless steel AISI 303

Seals

Polyurethane 92° shore hardness.
Options - Nitrile and Fluoroelastomer

Mountings

Aluminium alloy, epoxy coated.
Steel, zinc plated or galvanised.

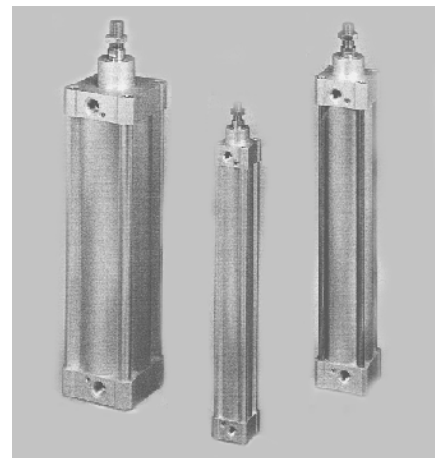

Service kits

Basic cylinders

32mm bore - M0321PSK
 40mm bore - M0401PSK
 50mm bore - M0501PSK
 63mm bore - M0631PSK
 80mm bore - M0801PSK
 100mm bore - M1001PSK
 125mm bore - M1251PSK
 160mm bore - M1601PSK
 200mm bore - M2001PSK

Cylinders with Nitrile seals

Change code 'P' in position 6 to code 'N' - i.e. M0321NSK

Cylinders with Fluoroelastomer seals

Change code 'P' in position 6 to code 'V' - i.e. M0321VSK

Through rod cylinders

Change code '1' in position 5 to code '4' - i.e. M0324PSK

Rear connection twin cylinders

Change code '1' in position 5 to code '5' - i.e. M0325PSK

Front connection twin cylinders

Change code '1' in position 5 to code '6' - i.e. M0326PSK

Positioner controlled cylinders

Details on application

Braking cylinders

Details on application.

Other models available

- 250mm and 320mm bore ISO cylinders.
- Linear Valve Actuators 125mm - 1010mm bore.



VDMA/ISO POWER CYLINDERS DOUBLE ACTING

VDMA
ISO
CYLINDERS

32, 40, 50, 63, 80, 100, 125, 160, 200mm bore

Cylinder sizing

Selection of suitable bore size

- 1 Establish thrust required and available working pressure of air supply. Determine whether static or dynamic application - *for dynamic applications it is recommended that a thrust of 30% in excess of required loading be allowed.*
- 2 Using the thrust tables given below
 - a) Select the working pressure
 - b) Select the thrust required - if exact thrust is not shown use nearest larger unit.
 - c) Read off cylinder bore size.

Theoretical thrust

Thrust in Newtons assuming a cylinder efficiency of 85%.

Bore mm	Direction	Air pressure - bar									
		1.0	2.0	3.0	4.0	5.0	6.0	7.0	8.0	9.0	10.0
32	EXTEND	68	137	205	273	342	410	478	547	615	683
	RETRACT	59	117	176	235	293	352	411	470	529	587
40	EXTEND	107	213	320	427	534	640	747	854	961	1068
	RETRACT	89	179	269	359	448	538	627	717	807	897
50	EXTEND	167	333	501	667	834	1000	1168	1335	1501	1668
	RETRACT	140	281	420	560	700	841	981	1121	1261	1401
63	EXTEND	265	530	795	1059	1324	1589	1854	2118	2383	2648
	RETRACT	238	476	714	952	1191	1429	1667	1905	2143	2381
80	EXTEND	427	854	1281	1709	2135	2562	2989	3416	3844	4270
	RETRACT	385	771	1156	1541	1927	2312	2697	3083	3468	3853
100	EXTEND	667	1335	2002	2669	3336	4004	4671	5338	6005	6673
	RETRACT	626	1251	1877	2502	3128	3753	4379	5004	5630	6253
125	EXTEND	1042	2084	3126	4168	5211	6253	7295	8337	9379	10421
	RETRACT	974	1948	2922	3896	4871	5845	6819	7793	8767	9741
160	EXTEND	1708	3415	5123	6831	8538	10246	11954	13661	15369	17077
	RETRACT	1573	3147	4720	6293	7867	9440	11013	12587	14160	15734
200	EXTEND	2669	5338	8007	10676	13345	16014	18683	21352	24021	26690
	RETRACT	2562	5125	7687	10249	12811	15373	17936	20498	23061	25622

Useful cylinder calculations

Thrust

$$T = P \times A \times E \times 10^3$$

A = Effective piston area (dm²)
C = Air consumption (dm³/sec)
E = Cylinder Efficiency

Air consumption

$$C = \frac{A \times L \times N \times (P + 1.013)}{101.3}$$

L = Stroke (mm)
N = Single strokes per second
P = Pressure (bar)

Air flow

$$Q = \frac{A \times L \times (P + 1.013)}{t \times 101.3}$$

Q = Air flow (dm³/sec) free air
T = Thrust (Newtons)
t = Time for single stroke (secs)

Useful conversions

1N = 0.102 kgf
1N = 0.225 lbf
1kgf = 9.807 N
1lbf = 0.454 kgf
1scfm = 0.472 dm³/sec

1psi = 0.069 bar
60 l/min = 1 dm³/sec
1kg/cm² = 0.981 bar
14.5 psi = 1 bar
1bar = 0.10 Mpa

Installation dimensions mm

Basic profile barrel cylinders

MP****1D*x****

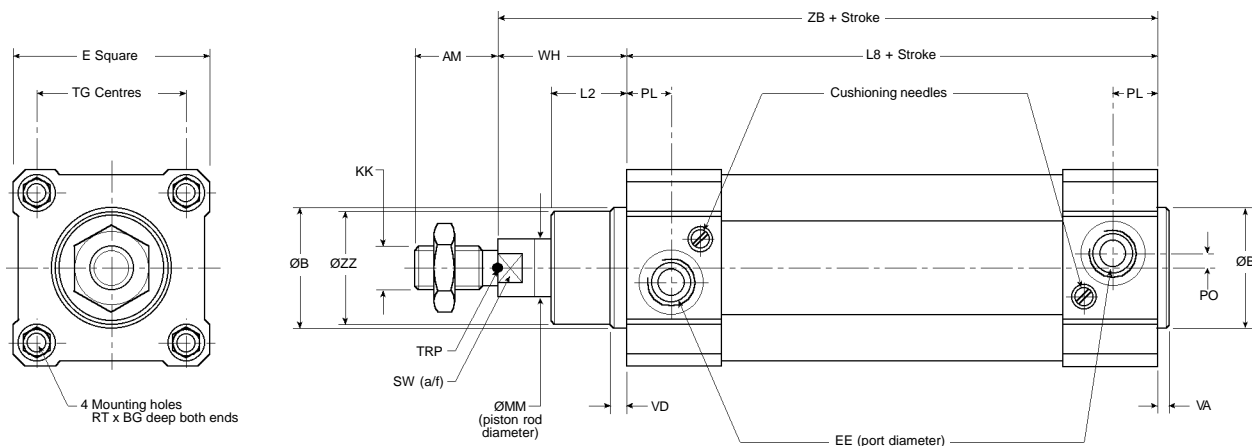

Note: Piston rod locknuts are supplied as standard

Basic round barrel cylinders

MR****1D*x****

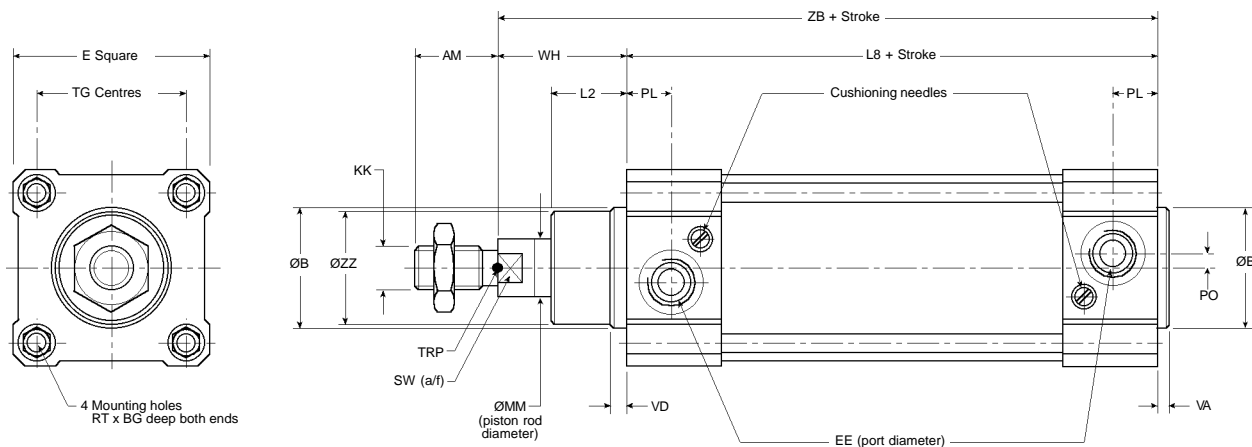

Note: Piston rod locknuts are supplied as standard

Bore	AM	B	BG	E	EE	KK	L2	L8	MM	PL	PO	SW	TG	RT	VA	VD	WH	ZB	ZZ
32	22	30	16	47	G1/8"	M10x1.25	17.5	94	12	13	4.5	10	32.5	M6	4	5	26	120	28
40	24	35	16	52	G1/4"	M12x1.25	20	105	16	14	4.5	13	38	M6	4	5	30	135	33
50	32	40	16	65	G1/4"	M16x1.5	25	106	20	14	6	17	46.5	M8	4	5	37	143	38
63	32	45	16	75	G3/8"	M16x1.5	25	121	20	20	6	17	56.5	M8	4	5	37	158	43
80	40	45	18	95	G3/8"	M20x1.5	33	128	25	18	7	22	72	M10	4	5	46	174	43
100	40	55	18	115	G1/2"	M20x1.5	38	138	25	20	7	22	89	M10	4	5	51	189	53
125	54	60	20	140	G1/2"	M27x2.0	50	160	32	30	13	27	110	M12	5	6	65	225	59
160	72	65	24	180	G3/4"	M36x2.0	50	180	40	28	0	36	140	M16	5	6	80	260	64
200	72	75	24	220	G3/4"	M36x2.0	60	180	40	28	0	36	175	M16	5	6	95	275	74

TRP = Theoretical Reference Point

Cylinder options

Double acting through rod

General description, operating data, technical data, materials of construction and service kits

All data is consistent with that for basic cylinders given on page 3.

Preferred models - Double acting through rod cylinders

Profile barrel, magnetic piston

Bore	Model code	Mass kg
32mm	MPE0324DP x Stroke	0.56 + 0.080/25mm
40mm	MPE0404DP x Stroke	0.84 + 0.120/25mm
50mm	MPE0504DP x Stroke	1.36 + 0.180/25mm
63mm	MPE0634DP x Stroke	2.04 + 0.188/25mm
80mm	MPE0804DP x Stroke	3.30 + 0.285/25mm
100mm	MPE1004DP x Stroke	5.06 + 0.315/25mm
125mm	MPE1254DP x Stroke	7.20 + 0.495/25mm
160mm	MPE1604DP x Stroke	14.00 + 0.800/25mm
200mm	MPE2004DP x Stroke	17.70 + 0.875/25mm

Round barrel, magnetic piston

Bore	Model code	Mass kg
32mm	MRE0324DP x Stroke	0.56 + 0.080/25mm
40mm	MRE0404DP x Stroke	0.84 + 0.120/25mm
50mm	MRE0504DP x Stroke	1.36 + 0.180/25mm
63mm	MRE0634DP x Stroke	2.04 + 0.188/25mm
80mm	MRE0804DP x Stroke	3.30 + 0.285/25mm
100mm	MRE1004DP x Stroke	5.06 + 0.315/25mm
125mm	MRE1254DP x Stroke	7.20 + 0.495/25mm
160mm	MRE1604DP x Stroke	14.00 + 0.800/25mm
200mm	MRE2004DP x Stroke	17.70 + 0.875/25mm

Profile barrel, non magnetic piston

Bore	Model code	Mass kg
32mm	MP0324DP x Stroke	0.56 + 0.080/25mm
40mm	MP0404DP x Stroke	0.84 + 0.120/25mm
50mm	MP0504DP x Stroke	1.36 + 0.180/25mm
63mm	MP0634DP x Stroke	2.04 + 0.188/25mm
80mm	MP0804DP x Stroke	3.30 + 0.285/25mm
100mm	MP1004DP x Stroke	5.06 + 0.315/25mm

Round barrel, non magnetic piston

Bore	Model code	Mass kg
32mm	MR0324DP x Stroke	0.56 + 0.080/25mm
40mm	MR0404DP x Stroke	0.84 + 0.120/25mm
50mm	MR0504DP x Stroke	1.36 + 0.180/25mm
63mm	MR0634DP x Stroke	2.04 + 0.188/25mm
80mm	MR0804DP x Stroke	3.30 + 0.285/25mm
100mm	MR1004DP x Stroke	5.06 + 0.315/25mm

Installation dimensions mm

Through rod profile barrel cylinders

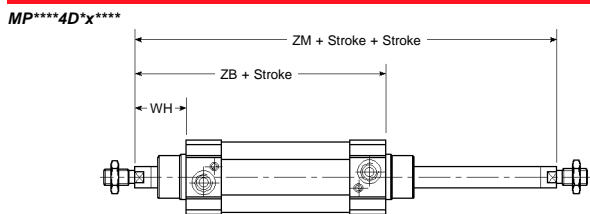

Note: Piston rod locknuts are supplied as standard

Bore	WH	ZB	ZM
32	26	120	146
40	30	135	165
50	37	143	180
63	37	158	195
80	46	174	220
100	51	189	240
125	65	225	290
160	80	260	340
200	95	275	370

All other dimensions as for basic cylinders (see page 6)

Through rod round barrel cylinders

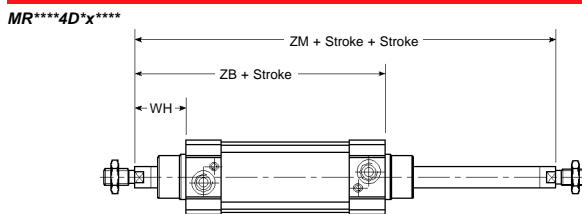

Note: Piston rod locknuts are supplied as standard

Bore	WH	ZB	ZM
32	26	120	146
40	30	135	165
50	37	143	180
63	37	158	195
80	46	174	220
100	51	189	240
125	65	225	290
160	80	260	340
200	95	275	370

All other dimensions as for basic cylinders (see page 6)

Cylinder options (cont)

Double acting rear connection, Double acting front connection

General description, operating data, technical data, materials of construction and service kits

All data is consistent with that for basic cylinders given on page 3.

Application Note: Rear and front connected cylinders will give 3 or 4 positive positions

Preferred models Double acting rear connection cylinders

Bore	Model code	Mass kg
32mm	M**0325DP x Stroke x Stroke	1.15 + 0.057/25mm
40mm	M**0405DP x Stroke x Stroke	1.65 + 0.080/25mm
50mm	M**0505DP x Stroke x Stroke	2.70 + 0.116/25mm
63mm	M**0635DP x Stroke x Stroke	4.05 + 0.127/25mm
80mm	M**0805DP x Stroke x Stroke	6.50 + 0.186/25mm
100mm	M**1005DP x Stroke x Stroke	10.10 + 0.218/25mm

Note (M):** MPE = Magnetic piston, profile barrel
MRE = Magnetic piston, round barrel
MP = Non magnetic piston, profile barrel
MR = Non magnetic piston, round barrel

Preferred models Double acting front connection cylinders

Bore	Model code	Mass kg
32mm	M**0326DP x Stroke x Stroke	1.15 + 0.057/25mm
40mm	M**0406DP x Stroke x Stroke	1.65 + 0.080/25mm
50mm	M**0506DP x Stroke x Stroke	2.70 + 0.116/25mm
63mm	M**0636DP x Stroke x Stroke	4.05 + 0.127/25mm
80mm	M**0806DP x Stroke x Stroke	6.50 + 0.186/25mm
100mm	M**1006DP x Stroke x Stroke	10.10 + 0.218/25mm

Note (M):** MPE = Magnetic piston, profile barrel
MRE = Magnetic piston, round barrel
MP = Non magnetic piston, profile barrel
MR = Non magnetic piston, round barrel

Installation dimensions mm

Rear connection cylinders

M*****5D*x****x****

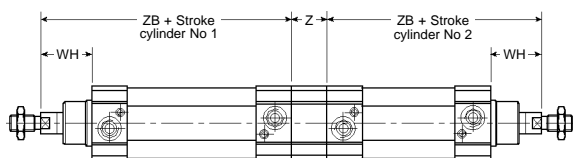

Note: Piston rod locknuts are supplied as standard

Bore	WH	Z	ZB
32	26	25	120
40	30	30	135
50	37	40	143
63	37	40	158
80	46	50	174
100	51	50	189

All other dimensions as for basic cylinders (see page 6)

Front connection cylinders

M*****6D*x****x****

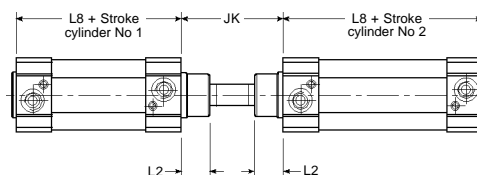

Bore	JK	L2	L8
32	92	17.5	94
40	100	20	105
50	124	25	106
63	124	25	121
80	152	33	128
100	162	38	138

All other dimensions as for basic cylinders (see page 6)



VDMA/ISO POWER CYLINDERS DOUBLE ACTING

VDMA
ISO
CYLINDERS

32, 40, 50, 63, 80, 100, 125, 160, 200mm bore

Cylinder options (cont)

Double acting high temperature cylinders

General description

All data is consistent with that for basic cylinders given on page 3 but fitted with fluoroelastomer seals.

Operating fluids

Consistent with that for basic cylinders given on page 3.

Technical data

Ambient operating temperature range
-10°C to +150°C (14°F to 302°F)

All other data is consistent with that for basic cylinders given on page 3.

Materials of construction

Seals

Fluoroelastomer

All other data is consistent with that for basic cylinders given on page 3.

Service kits

Change code 'P' in position 6 of basic cylinder kits shown on page 3 to code 'V' - i.e. M0321VSK

Preferred models High temperature basic cylinders

Bore	Model code	Mass kg
32mm	M**032*DV x Stroke	0.55 + 0.057/25mm
40mm	M**040*DV x Stroke	0.83 + 0.080/25mm
50mm	M**050*DV x Stroke	1.34 + 0.116/25mm
63mm	M**063*DV x Stroke	2.00 + 0.127/25mm
80mm	M**080*DV x Stroke	3.25 + 0.186/25mm
100mm	M**100*DV x Stroke	5.00 + 0.218/25mm
125mm	M**125*DV x Stroke	6.40 + 0.335/25mm
160mm	M**160*DV x Stroke	12.60 + 0.658/25mm
200mm	M**200*DV x Stroke	16.10 + 0.775/25mm

Note (M**): MPE = Magnetic piston, profile barrel (32 - 200mm bore)
MRE = Magnetic piston, round barrel (32 - 200mm bore)
MP = Non magnetic piston, profile barrel (32 - 100mm bore)
MR = Non magnetic piston, round barrel (32 - 100mm bore)

Safety note

Fluoroelastomer is a synthetic rubber which, if subjected to temperatures above 400°C (750°F), changes into a charred or sticky consistency containing Hydrofluoric acid.

This acid is extremely corrosive and once formed remains dangerous for years.

When dealing with components containing the material after a fire or similar very high temperature occurrence it is essential that protective gloves are worn and these are safely disposed of after use.

Installation dimensions

As for basic cylinders given on page 6.

Cylinder options (cont)

Double acting braking cylinders

General description and benefits

Double acting, single rod, fully adjustable cylinder with mechanical piston lock which can lock the rod at any point of its stroke.

Available with both profile barrels (MP range) or with conventional round barrels (MR range).

- Magnetic piston as standard.
- Accurate positioning.
- Fail safe (*Air pilot signal to release*).
- Static and dynamic braking.

Operating fluids

Consistent with that for basic cylinders given on page 3.

Technical data

Operating pressure (cylinder)

0.5 to 6 bar (7.25 to 87 psi)

Operating pressure (brake)

3.5 to 6 bar (50.75 to 87 psi)

Stopping precision

±1mm at cylinder speed of 300mm/sec at no load

Locking strength

32mm bore	600N
40mm bore	1000N
50mm bore	1500N
63mm bore	2200N
80mm bore	3000N
100mm bore	5000N
125mm bore	7000N

All other data is consistent with that for basic cylinders given on page 3.

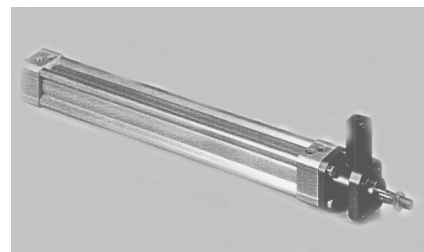

Materials of construction

Brake shoes

Special alloy shoes guarantee low wear and long service

All other data is consistent with that for basic cylinders given on page 3.

Service kits

Braking cylinders

Details on application.

Preferred models - Double acting braking cylinders

Profile barrel, magnetic piston

Bore	Model code	Mass kg
32mm	MPS0321DP x Stroke	0.78 + 0.057/25mm
40mm	MPS0401DP x Stroke	1.16 + 0.080/25mm
50mm	MPS0501DP x Stroke	2.00 + 0.116/25mm
63mm	MPS0631DP x Stroke	3.00 + 0.127/25mm
80mm	MPS0801DP x Stroke	5.37 + 0.186/25mm
100mm	MPS1001DP x Stroke	8.30 + 0.218/25mm
125mm	MPS1251DP x Stroke	12.40 + 0.335/25mm

Round barrel, magnetic piston

Bore	Model code	Mass kg
32mm	MRS0321DP x Stroke	0.78 + 0.057/25mm
40mm	MRS0401DP x Stroke	1.16 + 0.080/25mm
50mm	MRS0501DP x Stroke	2.00 + 0.116/25mm
63mm	MRS0631DP x Stroke	3.00 + 0.127/25mm
80mm	MRS0801DP x Stroke	5.37 + 0.186/25mm
100mm	MRS1001DP x Stroke	8.30 + 0.218/25mm
125mm	MRS1251DP x Stroke	12.40 + 0.335/25mm

Installation dimensions mm

Profile barrel braking cylinders, Round barrel braking cylinders

MPS***1D*x****
MRS***1D*x****

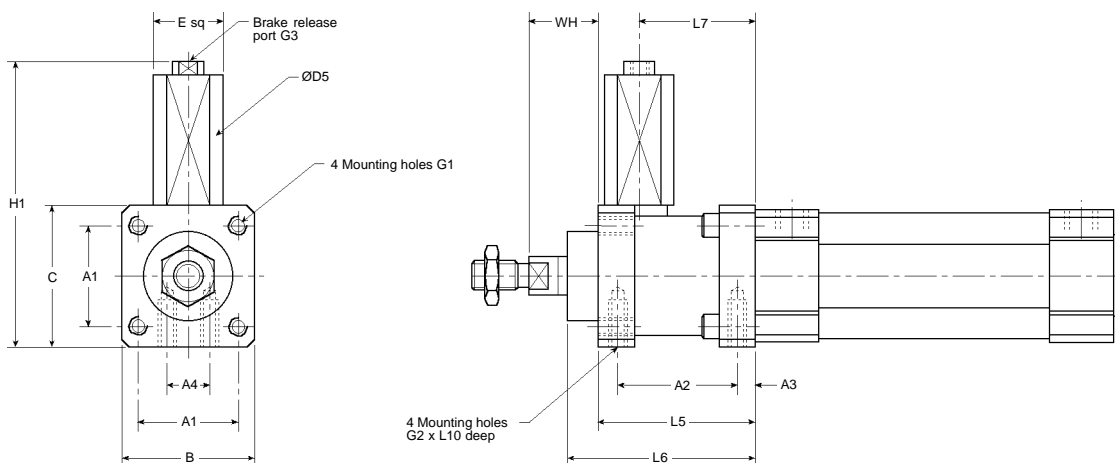

Note: Piston rod locknuts are supplied as standard

Bore	A1	A2	A3	A4	B	C	D5	E	G1	G2	G3	H1	L5	L6	L7	L10	WH
32	32.5	40	4.2	16	48	50	27.5	22.7	M6	M5	M5	96	48	58	32	8	26
40	38	46	4.5	21	56	58	31.5	27.7	M6	M5	M5	102	55	65	35.5	10	30
50	46.5	54	11.5	24	68	70	36	32.7	M8	M6	G1/8"	127	70	82	49	12	37
63	56.5	60	9.5	32	82	85	44	41.0	M8	M6	G1/8"	151.5	78	90	49	16	37
80	72	70	10	44	100	105	53	49.7	M10	M8	G1/8"	181.5	91.5	110	62	16	46
100	89	70	10	60	120	130	58	54.7	M10	M8	G1/8"	207	92	115	65	16	51
125	110	95	11	75	140	150	67.5	64.9	M12	M10	G1/8"	227	122	154	85	20	65

All other dimensions as for basic cylinders (see page 6)

Basic circuit diagram

For correct operation installation should be as shown right and following basic instructions adhered to:-

- a) When piston rod is stationary apply pressure to both sides of piston to prevent sudden surge of piston rod at moment of brake release - i.e. use pressure applied neutral valve for SOL 1.
- b) Install a regulator with check valve at larger thrust side to secure a balanced thrust and prevent piston rod movement at brake release prior to operation of SOL 1.
- c) Install the brake release solenoid valve SOL 2 (3/2 normally closed valve) as close to the brake port as possible.

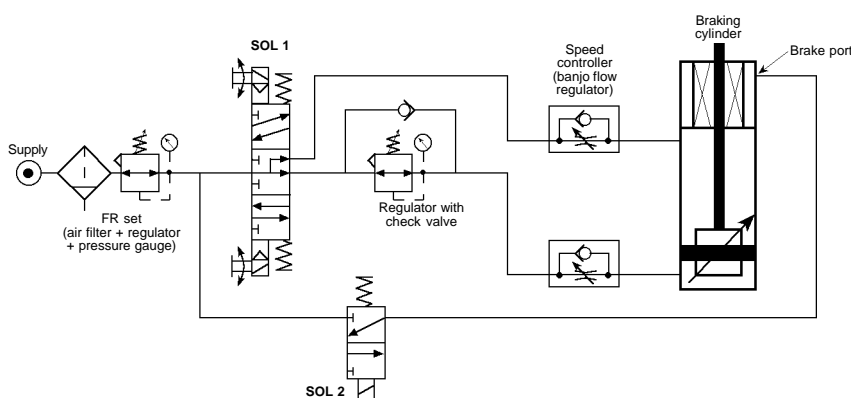

Operating condition	SOL1 (A)	SOL1 (B)	SOL2
Stop	OFF	OFF	OFF
Extend	ON	OFF	ON
Retract	OFF	ON	ON

Cylinder options (cont)

Double acting gaitered cylinders

General description, operating data, technical data, materials of construction and service kits

All data is consistent with that for basic cylinders given on page 3.

Preferred models

Basic gaitered cylinders

Bore	Model code	Mass kg
32mm	M**0321DPG* x Stroke	0.55 + 0.057/25mm (Cylinder stroke) + 0.25/100mm (Gaiter length)
40mm	M**0401DPG* x Stroke	0.83 + 0.080/25mm (Cylinder stroke) + 0.25/100mm (Gaiter length)
50mm	M**0501DPG* x Stroke	1.34 + 0.116/25mm (Cylinder stroke) + 0.25/100mm (Gaiter length)
63mm	M**0631DPG* x Stroke	2.00 + 0.127/25mm (Cylinder stroke) + 0.25/100mm (Gaiter length)
80mm	M**0801DPG* x Stroke	3.25 + 0.186/25mm (Cylinder stroke) + 0.30/100mm (Gaiter length)
100mm	M**1001DPG* x Stroke	5.00 + 0.218/25mm (Cylinder stroke) + 0.30/100mm (Gaiter length)
125mm	M**1251DPG* x Stroke	6.65 + 0.343/25mm (Cylinder stroke) + 0.30/100mm (Gaiter length)
160mm	M**1601DPG* x Stroke	12.20 + 0.526/25mm (Cylinder stroke) + 0.60/100mm (Gaiter length)
200mm	M**2001DPG* x Stroke	15.60 + 0.623/25mm (Cylinder stroke) + 0.60/100mm (Gaiter length)

Note (M):** MPE = Magnetic piston, profile barrel (32 - 200mm bore)
MRE = Magnetic piston, round barrel (32 - 200mm bore)
MP = Non magnetic piston, profile barrel (32 - 100mm bore)
MR = Non magnetic piston, round barrel (32 - 100mm bore)

Installation dimensions mm

Double acting gaitered cylinders

M*****1D*G*x****

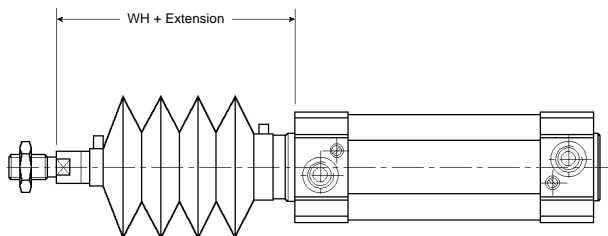

Piston rod extension (in mm) for stroke ranges shown

Stroke range reference letter (position 5 of model code - page 4):
A = 0 - 100mm, B = 101 - 200mm, C = 201 - 300mm, D = 301 - 400mm, E = 401 - 500mm, F = 501 - 600mm, G = 601 - 700mm, H = 701 - 800mm,
J = 801 - 900mm, K = 901 - 1000mm.

Bore	Stroke range reference letter									
	A	B	C	D	E	F	G	H	J	K
32	28	44	60	76	92	108	124	140	156	172
40	28	44	60	76	92	108	124	140	156	172
50	24	32	40	48	56	64	72	80	88	96
63	24	32	40	48	56	64	72	80	88	96
80	24	32	40	48	56	64	72	80	88	96
100	24	32	40	48	56	64	72	80	88	96
125	24	32	40	48	56	64	72	80	88	96
160	24	32	40	48	56	64	72	80	88	96
200	24	32	40	48	56	64	72	80	88	96

All other dimensions as for basic cylinders (see page 6)



VDMA/ISO POWER CYLINDERS DOUBLE ACTING

VDMA
ISO
CYLINDERS

32, 40, 50, 63, 80, 100, 125, 160, 200mm bore

Cylinder options (cont)

Double acting positioner controlled cylinders

General description and benefits

Pneumatic or electropneumatic positioner unit are available which enable the cylinder piston rod to be stroked to any position by varying the signal.

The positioning of the piston rod proportional to the signal can be achieved with accuracy and repeatability of $\leq 0.5\%$ of full stroke.

Operating fluids

Consistent with that for basic cylinders given on page 3.

Technical data

Operating pressure (cylinder)

1.4 to 10 bar (21 to 150 psi)

Signal pressure (pneumatic unit)

0.2 to 1.0 bar (3 to 15 psi)

Input signal (electropneumatic unit)

4 - 20mA

Linearity

$\leq 0.5\%$ of full scale

Hysteresis

$\leq 0.5\%$ of full scale

Repeatability

$\leq 0.5\%$ of full stroke

Connection ports

Screwthread 1/4" BSP

Cam characteristics

Linear

All other data is consistent with that for basic cylinders given on page 3.

Materials of construction

Positioner housing

Die cast aluminium

Surface treatment

ED Epoxy paint, black

Ingress protection

IP66 / NEMA 4

All other data is consistent with that for basic cylinders given on page 3.

Service kits

Details given on page 3.

Preferred models - Double acting positioner controlled cylinders

Electropneumatic control unit

Bore	Model code	Mass kg
40mm	M**0408DP** x Stroke	2.33 + 0.080/25mm
50mm	M**0508DP** x Stroke	2.84 + 0.116/25mm
63mm	M**0638DP** x Stroke	3.50 + 0.127/25mm
80mm	M**0808DP** x Stroke	4.75 + 0.186/25mm
100mm	M**1008DP** x Stroke	6.50 + 0.218/25mm
125mm	M**1258DP** x Stroke	7.90 + 0.335/25mm
160mm	M**1608DP** x Stroke	14.10 + 0.658/25mm
200mm	M**2008DP** x Stroke	17.60 + 0.775/25mm

Note (M**): MPE = Magnetic piston, profile barrel
MRE = Magnetic piston, round barrel

Note (††): CE = Cam extends with increase in signal pressure
CR = Cam retracts with increase in signal pressure

Pneumatic control unit

Bore	Model code	Mass kg
40mm	M**0409DP** x Stroke	1.93 + 0.080/25mm
50mm	M**0509DP** x Stroke	2.44 + 0.116/25mm
63mm	M**0639DP** x Stroke	3.10 + 0.127/25mm
80mm	M**0809DP** x Stroke	4.35 + 0.186/25mm
100mm	M**1008DP** x Stroke	6.10 + 0.218/25mm
125mm	M**1259DP** x Stroke	7.50 + 0.335/25mm
160mm	M**1609DP** x Stroke	13.70 + 0.658/25mm
200mm	M**2009DP** x Stroke	17.20 + 0.775/25mm

Note (M**): MPE = Magnetic piston, profile barrel
MRE = Magnetic piston, round barrel

Note (††): CE = Cam extends with increase in signal pressure
CR = Cam retracts with increase in signal pressure

Installation dimensions mm

Double acting positioner controlled cylinders

M****8D*G*x****

M****9D*G*x****

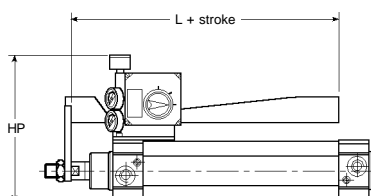
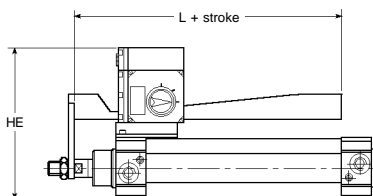

Bore	HE	HP	L(RH)	L(LH)
40	237	227	133	233
50	253	243	140	240
63	263	253	140	240
80	286	276	146	246
100	314	304	158	258
125	335	325	180	280
160	380	370	210	310
200	430	420	240	340

RH assembly standard as shown, please state if LH assembly required.

Feedback unit and IP Converter available for pneumatic units.
Explosion Proof, Intrinsically Safe and Fail Freeze versions available for electropneumatic units. Details of these and other variants on application.

All other dimensions as for basic cylinders (see page 6)

Mountings

Front (MF1) and rear (MF2) flange - to VDMA 24562 and ISO 6431

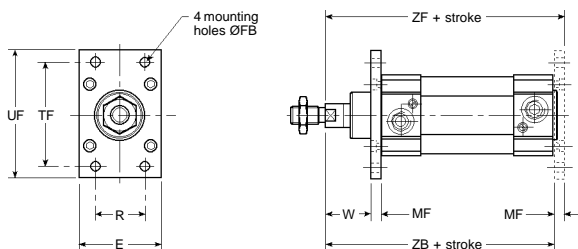

- Note:**
- 1) Kit number M*** - MF1K is suitable for front or rear fitment
 - 2) Kit supplied complete with fixing screws
 - 3) Material of construction - Mild Steel, Zinc plated

Model code, installation dimensions in mm

Bore	Kit number	E	FB	MF	R	TF	UF	W	ZB	ZF
32	M032 - MF1K	50	7	10	32	64	80	16	120	130
40	M040 - MF1K	55	9	10	36	72	90	20	135	145
50	M050 - MF1K	65	9	12	45	90	110	25	143	155
63	M063 - MF1K	75	9	12	50	100	120	25	158	170
80	M080 - MF1K	95	12	16	63	126	153	30	174	190
100	M100 - MF1K	115	14	16	75	150	178	35	189	205
125	M125 - MF1K	140	16	20	90	180	220	45	225	245
160	M160 - MF1K	180	18	20	115	230	270	60	260	280
200	M200 - MF1K	225	22	25	135	270	312	70	275	300

Feet (MS1) - to VDMA 24562 and ISO 6431

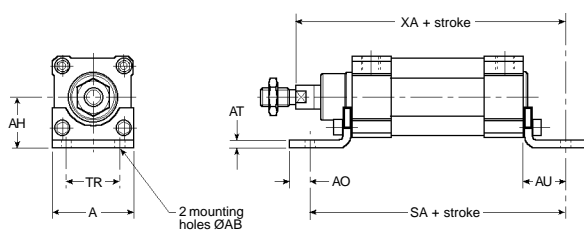

- Note:**
- 1) Kit M*** - MS1K is supplied as a pair
 - 2) Kit supplied complete with fixing screws
 - 3) Material of construction - Mild Steel, Zinc plated

Model code, installation dimensions in mm

Bore	Kit number	A	AB	AH	AO	AT	AU	SA	TR	XA
32	M032 - MS1K	45	7	32	11	5	24	142	32	144
40	M040 - MS1K	52	9	36	15	5	28	161	36	163
50	M050 - MS1K	65	9	45	15	6	32	170	45	175
63	M063 - MS1K	75	9	50	15	6	32	185	50	190
80	M080 - MS1K	95	12	63	20	7	41	210	63	215
100	M100 - MS1K	115	14	71	25	7	41	220	75	230
125	M125 - MS1K	140	16	90	15	8	45	250	90	270
160	M160 - MS1K	180	18	115	20	10	60	300	115	320
200	M200 - MS1K	220	22	135	30	10	70	320	135	375

Rear clevis (MP2) - to VDMA 24562 and ISO 6431

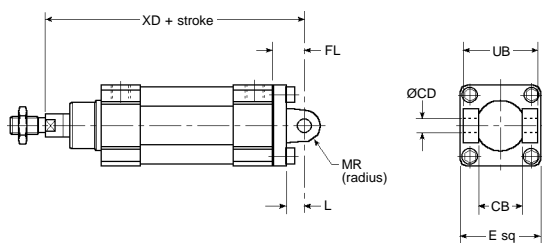

- Note:**
- 1) Pivot pin is supplied separately - see page 17
 - 2) Kit supplied complete with fixing screws
 - 3) Material of construction - Aluminium

Model code, installation dimensions in mm

Bore	Kit number	CB	CD	E	FL	L	MR	UB	XD
32	M032 - MP2K	26	10	45	22	12	11	45	142
40	M040 - MP2K	28	12	52	25	15	13	52	160
50	M050 - MP2K	32	12	65	27	15	13	60	170
63	M063 - MP2K	40	16	75	32	20	17	70	190
80	M080 - MP2K	50	16	95	36	20	17	90	210
100	M100 - MP2K	60	20	115	41	25	21	110	230
125	M125 - MP2K	70	25	140	50	30	26	130	275
160	M160 - MP2K	90	30	180	55	35	31	170	315
200	M200 - MP2K	90	30	220	60	35	31	170	335



VDMA/ISO POWER CYLINDERS DOUBLE ACTING

VDMA
ISO
CYLINDERS

32, 40, 50, 63, 80, 100, 125, 160, 200mm bore

Mountings (cont)

Rear eye (MP4) - to VDMA 24562 and ISO 6431

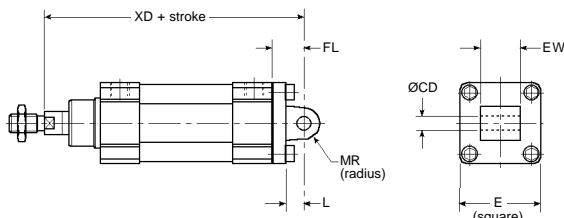

- Note:** 1) Pivot pin is supplied separately - see page 17
2) Kit supplied complete with fixing screws
3) Material of construction - Aluminium

Model code, installation dimensions in mm

Bore	Kit number	CD	E	EW	FL	L	MR	XD
32	M032 - MP4K	10	45	26	22	12	11	142
40	M040 - MP4K	12	52	28	25	15	13	160
50	M050 - MP4K	12	65	32	27	15	13	170
63	M063 - MP4K	16	75	40	32	20	17	190
80	M080 - MP4K	16	95	50	36	20	17	210
100	M100 - MP4K	20	115	60	41	25	21	230
125	M125 - MP4K	25	140	70	50	30	26	275
160	M160 - MP4K	30	180	90	55	35	31	315
200	M200 - MP4K	30	220	90	60	35	31	335

Rear hinge mount (MP2 + MP4 + Pivot pin) - to VDMA 24562 and ISO 6431

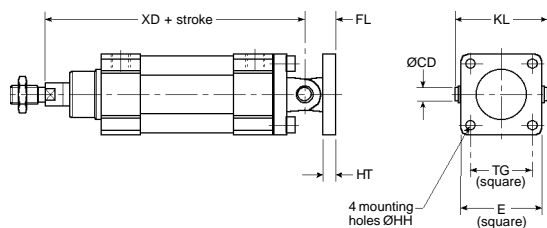

- Note:** 1) Kit supplied complete with fixing screws
2) Material of construction - Aluminium

Model code, installation dimensions in mm

Bore	Kit number	CD	E	FL	HH	HT	KL	TG	XD
32	M032 - MP24K	10	45	22	7	10	53	32.5	142
40	M040 - MP24K	12	52	25	7	10	60	38	160
50	M050 - MP24K	12	65	27	9	12	69	46.5	170
63	M063 - MP24K	16	75	32	9	12	80	56.5	190
80	M080 - MP24K	16	95	36	11	16	101	72	210
100	M100 - MP24K	20	115	41	11	16	121	89	230
125	M125 - MP24K	25	140	50	14	20	142	110	275
160	M160 - MP24K	30	180	55	18	20	184	140	315
200	M200 - MP24K	30	220	60	18	25	228	175	335

Rear 90° hinge (MP2 + 90° Bracket + Pivot pin) - to VDMA 24562 and ISO 6431

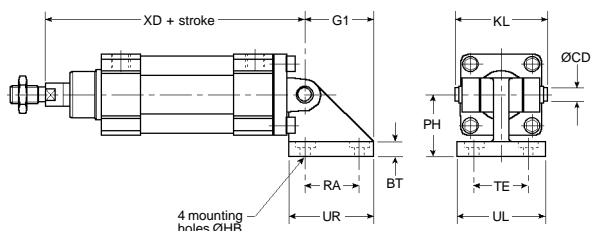

- Note:** 1) Kit supplied complete with fixing screws
2) Material of construction - Aluminium and Mild Steel, Zinc plated

Model code, installation dimensions in mm

Bore	Kit number	BT	CD	G1	HB	KL	PH	RA	TE	UL	UR	XD
32	M032 - MP29K	8	10	21	6.6	53	32	18	38	51	31	142
40	M040 - MP29K	10	12	24	6.6	60	36	22	41	54	35	160
50	M050 - MP29K	12	12	33	9	69	45	30	50	65	45	170
63	M063 - MP29K	14	16	37	9	80	50	35	52	67	50	190
80	M080 - MP29K	14	16	47	11	101	63	40	66	86	60	210
100	M100 - MP29K	17	20	55	11	121	71	50	76	96	70	230
125	M125 - MP29K	20	25	70	14	142	90	60	94	124	90	275

Mountings (cont)

Intermediate trunnion (MT4) - to VDMA 24562 and ISO 6431

Available for round barrel models **ONLY**

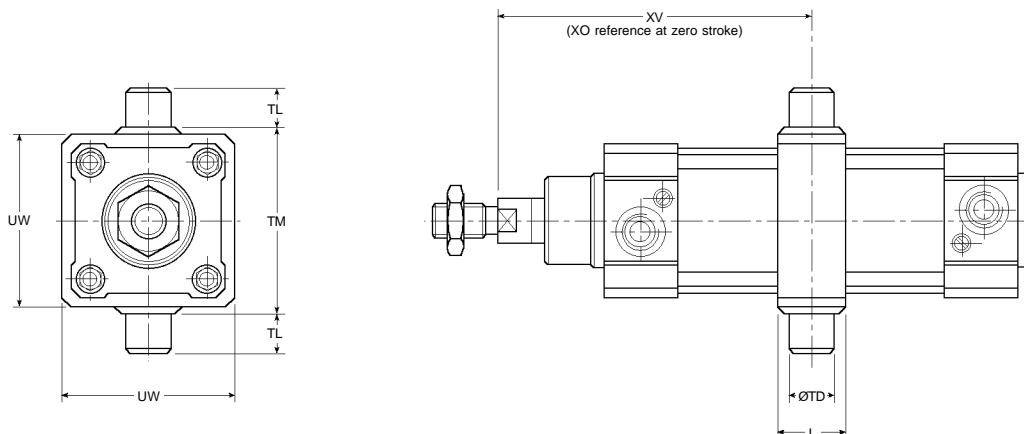

Trunnion pins are positioned at 90° to cylinder ports.
XO = reference dimension at zero stroke

Model code, installation dimensions in mm

Bore	Model code	L	TD	TL	TM	UW	XO	XV(min)	XV(max)
32	MR*0321DPMT4 x stroke	20	12	12	50	46	73	64.5	Stroke + 81.5
40	MR*0401DPMT4 x stroke	20	16	16	63	58	82.5	75	Stroke + 90
50	MR*0501DPMT4 x stroke	20	16	16	73	68	90	80	Stroke + 100
63	MR*0631DPMT4 x stroke	30	20	20	90	84	97.5	90	Stroke + 105
80	MR*0801DPMT4 x stroke	30	20	20	108	102	110	100	Stroke + 120
100	MR*1001DPMT4 x stroke	30	25	25	131	124	120	110	Stroke + 130
125	MR*1251DPMT4 x stroke	30	25	25	159	152	145	130	Stroke + 150
160	MR*1601DPMT4 x stroke	40	32	32	198	190	170	150	Stroke + 170
200	MR*2001DPMT4 x stroke	40	32	32	248	240	185	170	Stroke + 190

Note (M**): MRE = Magnetic piston, round barrel (32 - 200mm bore)
MR = Non Magnetic piston, round barrel (32 - 100mm bore)

Notes:

- When ordering, cylinder and trunnion must be ordered together and dimension XV **MUST** be specified. All cylinders will be given a unique SCM part number for dimensional traceability, if not mounted in central position.
- Trunnion supplied in central position as standard
 $XV = 1/2 \text{ stroke} + XO$.
- XV variations from the central position are supplied to special order - minimum and maximum permitted values are given in dimension table above.
- When trunnion is in extreme front or rear position magnetic sensors (if fitted) will not detect end of stroke at trunnion location.
- For twin cylinders of unequal stroke customer must specify which cylinder is to be fitted with trunnion mounting.



VDMA/ISO POWER CYLINDERS DOUBLE ACTING

VDMA
ISO
CYLINDERS

32, 40, 50, 63, 80, 100, 125, 160, 200mm bore

Accessories

Fork end with lockable pivot pin (32 - 100mm), Fork end with pivot pin (125 - 200mm)

32 - 100mm

125 - 200mm

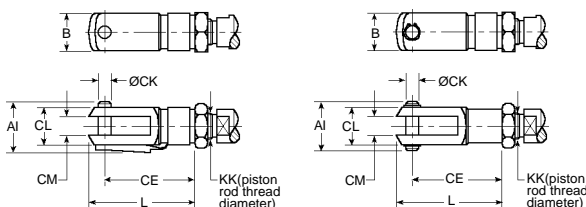

Model code, installation dimensions in mm

Bore	Kit number	AI	B	CE	CK	CL	CM	KK	L
32	M032 - FEK	26	20	40	10	20	10	M10x1.25	52
40	M040 - FEK	32	24	48	12	24	12	M12x1.25	62
50 & 63	M050 - FEK	38	32	64	16	32	16	M16x1.5	83
80 & 100	M080 - FEK	48	40	80	20	40	20	M20x1.5	105
125	M125 - FEK	65	55	100	30	55	30	M27x2.0	148
160 & 200	M160 - FEK	84	70	144	35	70	35	M36x2.0	188

Note: 1) Piston rod locknut provided as standard with cylinder
2) Material of construction - Mild Steel, Zinc plated

Rod spherical bearing - to ISO 8140

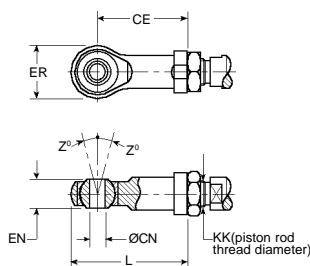

Model code, installation dimensions in mm

Bore	Kit number	CE	CN	EN	ER	KK	L	Z°
32	M032 - SREK	43	10	14	28	M10x1.25	57	6.5°
40	M040 - SREK	50	12	16	32	M12x1.25	66	6.5°
50 & 63	M050 - SREK	64	16	21	42	M16x1.5	85	7.5°
80 & 100	M080 - SREK	77	20	25	50	M20x1.5	102	7°
125	M125 - SREK	110	30	37	70	M27x2.0	145	8.5°
160 & 200	M160 - SREK	125	35	42	80	M36x2.0	165	9.5°

Note: 1) Piston rod locknut provided as standard with cylinder
2) Material of construction - Mild Steel, Zinc plated

Pivot pin

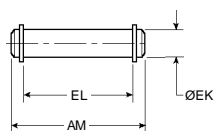

Pivot pin is supplied complete with retaining clips

Model code, installation dimensions in mm

Bore	Kit number	AM	EK	EL
32	M032 - PPK	53	10	46
40	M040 - PPK	60	12	52
50	M050 - PPK	69	12	61
63	M063 - PPK	80	16	71
80	M080 - PPK	101	16	91
100	M100 - PPK	121	20	111
125	M125 - PPK	142	25	132
160	M160 - PPK	184	30	172
200	M200 - PPK	228	30	172

Piston rod locknut

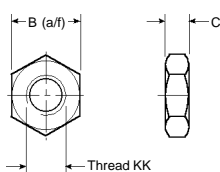

Model code, installation dimensions in mm

Bore	Kit number	B	C	KK
32	M032 - 9	17	6	M10x1.25
40	M040 - 9	19	7	M12x1.25
50 & 63	M050 - 9	24	9	M16x1.5
80 & 100	M080 - 9	30	10	M20x1.5
125	M125 - 9	41	12	M27x2
160 & 200	M160 - 9	55	14	M36x2

Magnetic sensors

Reed switch

General description

Reed switches with LED indicator and miniature 90° connector with 2 metre flying lead.

Switch is fitted to the profile barrel by means of an adaptor clamp or to the cylinder tie rods by means of a clamp assembly.

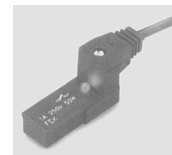

Preferred models

Reed switch

Code	Description
FEK110A0RP2	Reed switch with miniature 90° connector

Fixings

Code	Description
FA51-1131	Adaptor clamp for profile tube (32mm - 40mm bore cylinders)
FA51-1232	Adaptor clamp for profile tube (50mm bore cylinders)
FA51-1237	Adaptor clamp for profile tube (63mm - 80mm bore cylinders)
FA51-1337	Adaptor clamp for profile tube (100mm - 125mm bore cylinders)
FA51-1437	Adaptor clamp for profile tube (160mm - 200mm bore cylinders)
FA44-0009	Tie rod clamp (32mm - 63mm bore cylinders)
FA44-0015	Tie rod clamp (80mm - 125mm bore cylinders)
FA44-0020	Tie rod clamp (160mm - 200mm bore cylinders)

Circuit diagrams of switches

Reed switch

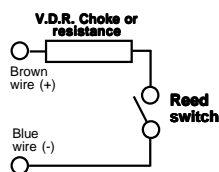

Warning:

For cable runs over 5m protect switch from inrush either by using a 680mH choke or a resistor fitted in series.
For inductive loads a voltage dependent resistor with a higher clamping voltage than the supply must be used.
Protection must be fitted within 2m of the switch.

Technical data

Ambient operating temperature range

-30° C to +80° C (-22° F to +176° F)

Contact function

Normally open

Protection

IP65

Nominal voltage

3 - 250VDC

3 - 250VAC

Switching current

1000mA

Maximum power

50w / 50VA

Switch ON time

2 milliseconds

Switch OFF time

0.1 milliseconds

Electrical life

10 x 10⁶ cycles

Resistance to vibration

1000Hz

Magnetic field

Intensity decreased by 2% for every 10°C (18°F) rise in operating temperature

Coating material

PA + 30% GF

LED indication

Red - 'ON'

Installation dimensions mm

Switch FEK110A0RP2

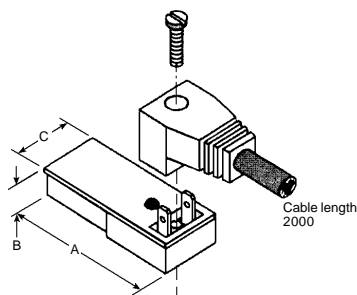

Model	A	B	C
FEK110A0RP2	33	7.4	12.9

Adaptor clamp FA51-****

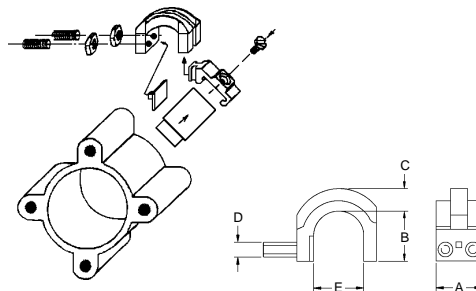

Model	A	B	C	D	E
FA51-1131	14	12	6	M4 x 10	12.2
FA51-1232	14	15.5	7	M4 x 10	15.5
FA51-1237	14	15.5	7	M4 x 10	15.5
FA51-1337	14	19.5	7	M4 x 20	20
FA51-1437	14	23	7	M4 x 20	26

Tie rod clamp FA44-****

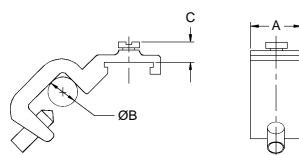

Model	A	B (min)	B (max)	C (max)
FA44-0009	14	4	9	5.5
FA44-0015	14	9	15	5.5
FA44-0020	14	15	20	5.5



VDMA/ISO POWER CYLINDERS DOUBLE ACTING

VDMA
ISO
CYLINDERS

MIDLAND PNEUMATIC

**Specials are Standards . . .
...And our Standards are Special**



Presented By:



Patrick Gregory Road, Wednesfield, Wolverhampton WV11 3DZ England
Tel: +44 (0) 1902 305678 Fax: +44 (0) 1902 305676
E mail: sales@imc-uk.com Web site: <http://www.midland-pneu.com>

6260 E Riverside Boulevard, Rockford, IL 61111 U.S.A.
Tel: +1-815-636-8791 Fax: +1-815-636-8792
E mail: midlandusa@inwave.com



Ref: VDMA/02/01

An **IMC** Company