

Rotary Plug Valves (PR Series)

Catalog 4126-PR
Revised, March 2002



PR Series Rotary Plug Valves

Introduction

Parker PR Series Plug Valves provide positive leak tight shut-off, high flow capacity, and quick quarter-turn operation in a compact attractive package. The patented blow-out resistant seat design offers reliable sealing technology at all operating pressures. In addition to on-off actuation, the plug design allows forward flow throttling. A selection of valve seat and seal materials may be chosen for media compatibility and performance over a broad range of temperatures. The pressure balanced atmospheric seals are backed by PTFE rings to enhance their performance and increase cycle life.

Features

- Patented blow-out resistant seat design
- Pressures up to 3,000 psig (207 bar) CWP
- Quarter-turn operation
- Reliable simple design
- Straight-through flow
- Stainless steel and brass construction
- Nitrile, ethylene propylene, fluorocarbon, and highly fluorinated fluorocarbon rubber seats and seals
- PTFE back-up rings on atmospheric seals
- Low operating torque
- Minimum pressure drop
- Throttling capability
- Positive handle stops
- Color coded fracture resistant nylon handles with directional flow indication
- Easy to service
- 100% factory tested
- Options include lock-out devices, downstream venting, and both stainless steel and T-bar handles

Specifications

- Pressure Ratings:
 - Normal Flow Direction: 3000 psig (207 bar) CWP
 - Reverse Flow Direction: 150 psig (10 bar)
 - Downstream Vent Option: 150 psig (10 bar)

Open



Closed



Model Shown: **4A-PR4-VT-SS**

U.S. Patent 5,234,193

Available End Connections

Z-Single ferrule CPI™
compression port



A-Two ferrule A-LOK®
compression port



V-VacuSeal face
seal port



F-ANSI/ASME B1.20.1
Internal pipe threads



M-ANSI/ASME B1.20.1
External pipe threads



Q-UltraSeal face
seal port



PR Series Rotary Plug Valves

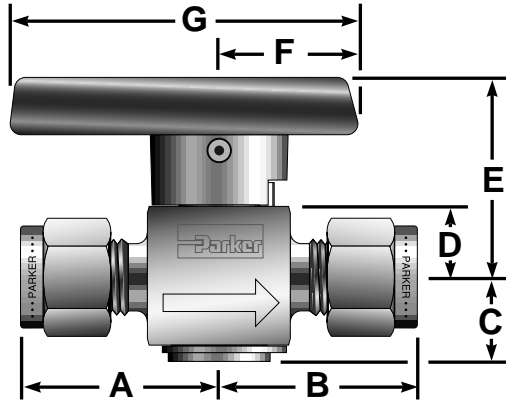

Model Shown: 4A-PR4-VT-B

Flow Data / Dimensions

Port Size	Basic Part No.	Flow Data				End Connections		Dimensions Inches (mm)						
		Orifice		C_v	X_T^\dagger	Port 1	Port 2	A [†]	B [†]	C	D	E	F	G
Inch	mm	Inch	mm											
2F	PR4	0.193	4.9	1.24	0.39	1/8" Female NPT	0.89 (22.6)	0.89 (22.6)	0.46 (11.7)	0.38 (9.7)	1.07 (27.2)	0.75 (19.1)	1.88 (47.8)	
2M		0.172	4.4	1.02	0.39	1/8" Male NPT	0.77 (19.6)	0.77 (19.6)						
2A		0.093	2.4	0.22	0.48	1/8" A-LOK [®]	1.00	1.00						
2Z						1/8" CPI [™]	(25.4)	(25.4)						
4F		0.193	4.9	1.24	0.39	1/4" Female NPT	1.05 (26.7)	1.05 (26.7)						
4M		0.193	4.9	1.24	0.39	1/4" Male NPT	0.96 (24.4)	0.96 (24.4)						
4A		0.187	4.7	1.18	0.41	1/4" A-LOK [®]	1.09	1.09						
4Z						1/4" CPI [™]	(27.7)	(27.7)						
4Q		0.187	4.7	1.18	0.41	1/4" UltraSeal	0.85 (21.7)	0.85 (21.7)						
4V		0.187	4.7	1.18	0.41	1/4" VacuSeal	1.02 (25.9)	1.02 (25.9)						
6M		0.193	4.9	1.24	0.39	3/8" Male NPT	0.94 (23.9)	0.94 (23.9)						
6A		0.193	4.9	1.24	0.39	3/8" A-LOK [®]	1.14	1.14						
6Z						3/8" CPI [™]	(29.0)	(29.0)						
M3A		0.086	2.2	0.15	0.48	3mm A-LOK [®]	0.98	0.98						
M3Z						3mm CPI [™]	(24.9)	(24.9)						
M6A		0.188	4.8	1.18	0.41	6mm A-LOK [®]	1.08	1.08						
M6Z						6mm CPI [™]	(27.4)	(27.4)						
M8A		0.193	4.9	1.24	0.48	8mm A-LOK [®]	1.11	1.11						
M8Z	8mm CPI [™]					(28.2)	(28.2)							
4F	PR6	0.281	7.1	3.19	0.28	1/4" Female NPT	1.19 (30.2)	1.19 (30.2)	0.67 (17.0)	0.56 (14.2)	1.49 (37.8)	0.99 (25.1)	2.40 (61.0)	
6A		0.281	7.1	3.19	0.28	3/8" A-LOK [®]	1.33	1.33						
6Z						3/8" CPI [™]	(33.8)	(33.8)						
8F		0.281	7.1	3.19	0.28	1/2" Female NPT	1.44 (36.6)	1.44 (36.6)						
8M		0.281	7.1	3.19	0.28	1/2" Male NPT	1.32 (33.5)	1.32 (33.5)						
8A		0.281	7.1	3.19	0.28	1/2" A-LOK [®]	1.44	1.44						
8Z						1/2" CPI [™]	(36.6)	(36.6)						
M8A		0.250	6.4	2.84	0.29	8mm A-LOK [®]	1.30	1.30						
M8Z						8mm CPI [™]	(33.0)	(33.0)						
M10A		0.281	7.1	3.19	0.28	10mm A-LOK [®]	1.34	1.34						
M10Z						10mm CPI [™]	(34.0)	(34.0)						
M12A		0.281	7.1	3.19	0.28	12mm A-LOK [®]	1.47	1.47						
M12Z	12mm CPI [™]					(37.3)	(37.3)							

† For CPI[™] and A-LOK[®], dimensions are measured with nuts in the finger tight position.

‡ Tested in accordance with ISA S75.02. Gas flow will be choked when $P_1 - P_2 / P_1 = X_T$.

PR Series Rotary Plug Valves

How to Order

The correct part number is easily derived from the following number sequence. The six product characteristics required are coded as shown below. *Note: If the inlet and outlet ports are the same, eliminate the outlet port designator.

Example: **4Z** * - **PR4** - **BN** **T** - **SS**
 ① ② ③ ④ ⑤ ⑥
Inlet **Outlet** **Valve** **Seal** **Back-Up** **Body**
Port **Port** **Series** **Material** **Rings** **Material**

Describes a PR Series rotary plug valve equipped with 1/4" CPI™ compression inlet and outlet ports, Buna-N seals, PTFE back-up rings, and stainless steel construction.

① Inlet Port	② Outlet Port	③ Valve Series	④ Seal Material	⑤ Back-Up Rings	⑥ Body Material
2F, 2M, 2A, 2Z, 4F, 4M, 4A, 4Z, 4Q, 4V, 6M, 6A, 6Z, M3A, M3Z, M6A, M6Z, M8A, M8Z		PR4	V- Fluorocarbon Rubber KZ- Highly Fluorinated	T- PTFE	SS- Stainless Steel
4F, 6A, 6Z, 8F, 8M, 8A, 8Z, M8A, M8Z, M10A, M10Z, M12A, M12Z		PR6	Fluorocarbon Rubber EPR- Ethylene Propylene Rubber BN- Buna-N Rubber		B - Brass

Options

Lock-Out Device

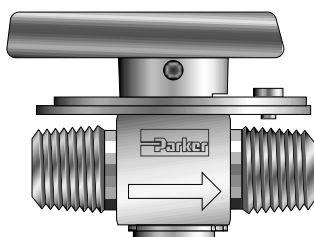

Used to lock the handle from accidental rotation in either the opened or closed position. To order the device with the valve, add the suffix **-LD** to the end of the part number.

Example and model shown: 4M-PR4-VT-B-LD. To order the device separately, specify **LD-PR4** or **LD-PR6**.

T-Bar Handle

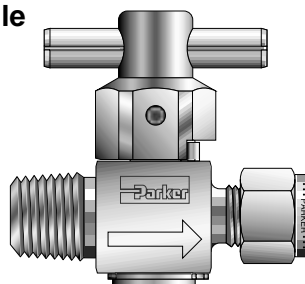

An all metal bar stock design for higher strength and durability. Consists of a stainless steel pin and aluminum adapter. To order, add the suffix **-T** to the end of the part number. **Example and model shown:** 4M4A-PR4-EPRT-SS-T.

Downstream Venting – As the valve is positioned from opened to closed, downstream pressure is released to atmosphere through a vent hole in the body and plug. The maximum recommended operating pressure for this option is 150 psig (10 bar). To order, insert **V** after PR in the model number. **Example:** 4A-PRV4-VT-B

Colored Handles – Black is the standard color. Add the designator corresponding to the correct handle color as a suffix to the part number: **W** – white, **B** – blue, **G** – green, **R** – red, **Y** – yellow. **Example:** M6A-PR4-BNT-SS-G

Stainless Steel Directional Handles – A stainless steel handle with the same design configuration as the standard nylon handle is available for the PR4 series. Add the designator **-ST** as a suffix to the part number. **Example:** 4Q-PR4-EPRT-SS-ST

WARNING

FAILURE, IMPROPER SELECTION OR IMPROPER USE OF THE PRODUCTS AND/OR SYSTEMS DESCRIBED HEREIN OR RELATED ITEMS CAN CAUSE DEATH, PERSONAL INJURY AND PROPERTY DAMAGE.

This document and other information from Parker Hannifin Corporation, its subsidiaries and authorized distributors provide product and/or system options for further investigation by users having technical expertise. It is important that you analyze all aspects of your application and review the information concerning the product or system in the current product catalog. Due to the variety of operating conditions and applications for these products or systems, the user, through its own analysis and testing, is solely responsible for making the final selection of the products and systems and assuring that all performance, safety and warning requirements of the application are met.

The products described herein, including without limitation, product features, specifications, designs, availability and pricing, are subject to change by Parker Hannifin Corporation and its subsidiaries at any time without notice.

Offer of Sale

The items described in this document are hereby offered for sale by Parker Hannifin Corporation, its subsidiaries or its authorized distributors. This offer and its acceptance are governed by the provisions stated in the "Offer of Sale" located in Catalog 4110-U Needle Valves (U Series).

© Copyright 2002, Parker Hannifin Corporation. All Rights Reserved.

Materials of Construction

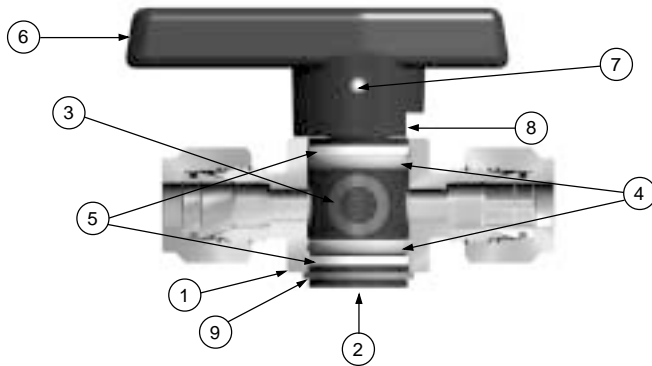

Model Shown: 4A-PR4-VT-SS

Item #	Part Description	Stainless Steel	Brass
1	Body	ASTM A 479 Type 316	ASTM B 16 Alloy C36000
2	Plug*	ASTM A 479 Type 316	ASTM B 16 Alloy C36000
3	Seat**	Fluorocarbon Rubber	
4	O-ring Seals**	Fluorocarbon Rubber	
5	Back-up Rings	PTFE	
6	Handle	Nylon 6/6	
7	Handle Pin	316 Stainless Steel	
8	Body Pin	316 Stainless Steel (Not shown)	
9	Retaining Ring	316 Stainless Steel	

* Plugs are PTFE color coated – Stainless steel plugs are black; Brass plugs are brown.

** Optional Seat and O-ring seal materials are available.
Lubrication: Perfluorinated polyether

Note: This Pressure versus Temperature chart reflects the maximum temperature range of indicated body materials.

The temperature rating of the elastomer seals become the limiting factor on temperature range.

• Temperature Ratings:

Buna-N Rubber:
-30 °F to 225 °F (-34 °C to 107 °C)

Fluorocarbon Rubber:
-10 °F to 450 °F (-23 °C to 232 °C)

Highly Fluorinated Fluorocarbon Rubber:
-10 °F to 300 °F (-23 °C to 149 °C)

Ethylene Propylene Rubber:
-70 °F to 275 °F (-57 °C to 135 °C)

Pressure vs. Temperature

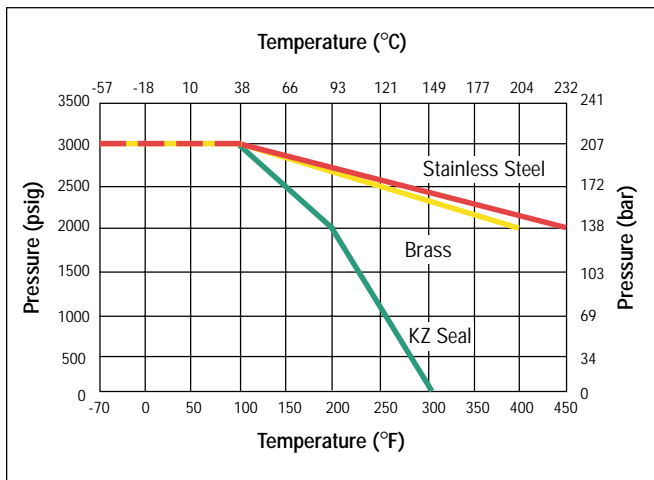

Note: To determine MPa, multiply bar by 0.1

Flow Calculations with 1000 psig (69 bar) Inlet Pressure

Valve Series	Maximum Cv	Pressure Drop Δ P		Water @ 60 °F (16 °C)		Air @ 60 °F (16 °C)	
		psig	bar	gpm	m ³ /hr	scfm	m ³ /hr
PR4	1.24	10	0.7	3.9	0.9	123.1	209.6
		50	3.4	8.8	2.0	265.9	446.3
		100	6.9	12.4	2.8	359.6	607.0
PR6	3.19	10	0.7	10.1	2.3	315.7	533.5
		50	3.4	22.6	5.1	672.3	1128.2
		100	6.9	31.9	7.2	891.6	1504.1



Kits

Plug Kits – Specify the combination of valve series, seal material, plug material, and handle color (if applicable).

Example: KIT-PR4-VT-SS-Y. This kit consists of a PR4 stainless steel plug with fluorocarbon rubber seat and seal elastomers, PTFE back-up rings, yellow handle, and handle pin.

Seal Kits – Specify the combination of valve series and seal material. **Example:** KIT-PR4-BN. This kit consists of a PR4 Buna-N rubber seat and seal elastomers and PTFE back-up rings.



Catalog 4126-PR, 20M, 03/02

Parker Hannifin Corporation
Instrumentation Valve Division
2651 Alabama Highway 21 North
Jacksonville, AL 36265-9681
USA
Phone: (256) 435-2130
Fax: (256) 435-7718
www.parker.com/IVD



Parker Hannifin plc
Instrumentation Products Division
Riverside Road
Pottington Business Park
Barnstaple, Devon EX31 1NP
England
Phone: +44 (0) 1271 313131
Fax: +44 (0) 1271 373636
Email: ipd@parker.com
www.parker.com/IPD

