



# ***Ball Valves (B Series)***

*Catalog 4121-B  
May 2005*



## Pressure vs. Temperature

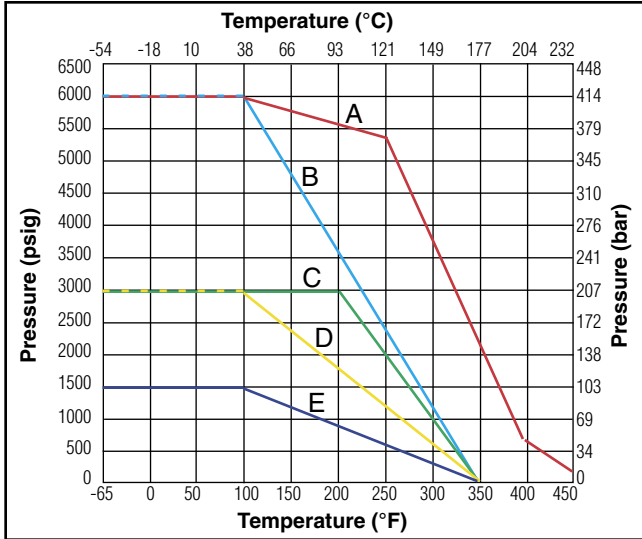

**Legend:** A – PEEK Seats; B – PCTFE Seats; C – Selector Valves; D – Brass Valves; E – PTFE Seats  
**Note:** To determine MPa, multiply bar by 0.1

**Note:** This Pressure versus Temperature chart reflects the maximum temperature range of indicated materials.

When combining seat and seal materials, the most restrictive temperature rating of the seats or seals becomes the limiting factor on valve temperature range.

Elastomeric stem packing and seals are recommended if the application subjects the valve to thermal cycling.

Please see pages 2 and 4 for maximum pressure ratings.

### Temperature Ratings:

- PTFE: ..... -65°F to 350°F (-54°C to 177°C)
- PCTFE:..... -65°F to 350°F (-54°C to 177°C)
- PEEK:..... -65°F to 450°F (-54°C to 232°C)
- Nitrile Rubber:..... -40°F to 250°F (-40°C to 121°C)
- Fluorocarbon Rubber:..... -15°F to 450°F (-26°C to 232°C)
- Ethylene Propylene Rubber:.... -65°F to 300°F (-54°C to 149°C)
- Highly Fluorinated Fluorocarbon Rubber ..... -15°F to 200°F (-26°C to 93°C)

## Flow Calculations with 1000 psig (69 bar) Inlet Pressure

### Two-Way

Valve Series	Max. C <sub>v</sub>	Pressure Drop ΔP		Water @ 60°F (16°C)		Air @ 60°F (16°C)	
		psig	bar	gpm	m <sup>3</sup> /hr	scfm	m <sup>3</sup> r
B2L	0.93	10	0.7	2.9	0.7	92.4	156.2
		50	3.5	6.6	1.5	200.3	338.3
		100	6.9	9.3	2.1	272.0	458.9
B6L	2.34	10	0.7	7.4	1.7	231.7	391.5
		50	3.5	16.5	3.8	494.2	834.7
		100	6.9	23.4	5.3	657.0	1107.9
B8L	6.42	10	0.7	20.3	4.6	637.1	1076.8
		50	3.5	45.4	10.3	1373.6	2320.3
		100	6.9	64.2	14.6	1852.3	3124.8

### Three-Way

Valve Series	Max. C <sub>v</sub>	Pressure Drop ΔP		Water @ 60°F (16°C)		Air @ 60°F (16°C)	
		psig	bar	gpm	m <sup>3</sup> /hr	scfm	m <sup>3</sup> r
B2X	0.63	10	0.7	2.0	0.5	62.7	106.0
		50	3.5	4.5	1.0	137.1	231.7
		100	6.9	6.3	1.4	188.4	317.9
B6X	0.87	10	0.7	2.8	0.6	86.7	146.6
		50	3.5	6.2	1.4	190.5	321.8
		100	6.9	8.7	2.0	263.2	444.4
B8X	3.62	10	0.7	11.5	2.6	360.6	609.5
		50	3.5	25.6	5.9	789.7	1343.5
		100	6.9	36.2	8.2	1087.4	1836.6

### ! WARNING

FAILURE OR IMPROPER SELECTION OR IMPROPER USE OF THE PRODUCTS AND/OR SYSTEMS DESCRIBED HEREIN OR RELATED ITEMS CAN CAUSE DEATH, PERSONAL INJURY AND PROPERTY DAMAGE.

This document and other information from Parker Hannifin Corporation, its subsidiaries and authorized distributors provide product and/or system options for further investigation by users having technical expertise. It is important that you analyze all aspects of your application and review the information concerning the product or system in the current product catalog. Due to the variety of operating conditions and applications for these products or systems, the user, through its own analysis and testing, is solely responsible for making the final selection of the products and systems and assuring that all performance, safety and warning requirements of the application are met.

The products described herein, including without limitation, product features, specifications, designs, availability and pricing, are subject to change by Parker Hannifin Corporation and its subsidiaries at any time without notice.

### Offer of Sale

The items described in this document are hereby offered for sale by Parker Hannifin Corporation, its subsidiaries or its authorized distributors. This offer and its acceptance are governed by the provisions stated in the "Offer of Sale" located in Catalog 4230/4233 CPI™/A-Lok® Tube Fittings.

## Introduction

Parker manually, pneumatically, and electrically actuated two-way B Series Ball Valves provide quick 1/4 turn on-off control of fluids utilized in process and instrumentation applications. A broad selection of valve body, seat, and seal materials provide a wide range of pressures and temperatures at which the valve may be used.

## Features

- ▶ Free floating ball design provides seat wear compensation.
- ▶ Available in 316 stainless steel and brass construction. Alloy N24135 and Alloy N30002 construction available upon request.
- ▶ Micro-finished ball provides a positive seal.
- ▶ Straight through flow path for minimum pressure drop.
- ▶ Bi-directional flow.
- ▶ Wide variety of US Customary and SI ports.
- ▶ 90 degree actuation.
- ▶ Panel mountable.
- ▶ Adjustable PTFE stem seal can be maintained in-line.
- ▶ Handle indicates flow direction.
- ▶ Low operating torques.
- ▶ Positive handle stops.
- ▶ Color coded handles.
- ▶ Optional pneumatic and electric actuation.
- ▶ Optional live-loaded PTFE stem seals.
- ▶ Optional non-adjustable O-ring stem seals.
- ▶ Optional upstream and downstream drain models.
- ▶ Optional stainless steel and extended handles.

## Specifications

### Pressure Ratings:

Material	CWP	with PTFE Seats
316 Stainless Steel	6000 psig (414 bar)*	1500 psig (103 bar)
Brass	3000 psig (207 bar)	1500 psig (103 bar)
Alloy N24135 (400)		
B2 and B6:	3000 psig (207 bar)	1500 psig (103 bar)
B8:	2000 psig (138 bar)	1500 psig (103 bar)
Alloy N30002 (C-276)		
B2 and B6:	4000 psig (276 bar)	1500 psig (103 bar)
B8:	3000 psig (207 bar)	1500 psig (103 bar)

\* B6 Series: 6000 psig rating or 4400 psig (303 bar) CWP  
B8 Series: 6000 psig rating or 4000 psig (276 bar) CWP

### Pressure Rating and Tubing Selection

For working pressures of A-LOK® and CPI™ tube connections, please see the Instrument Tubing Selection Guide (Bulletin 4200-TS), found in the Technical Section of the Parker Instrumentation Process Control Binder, or the Parker Instrument Fitting Installation Manual (Bulletin 4200-B4).

For working pressures of valves with external or internal pipe threads, please see Catalog 4260, Instrumentation Pipe Fittings.

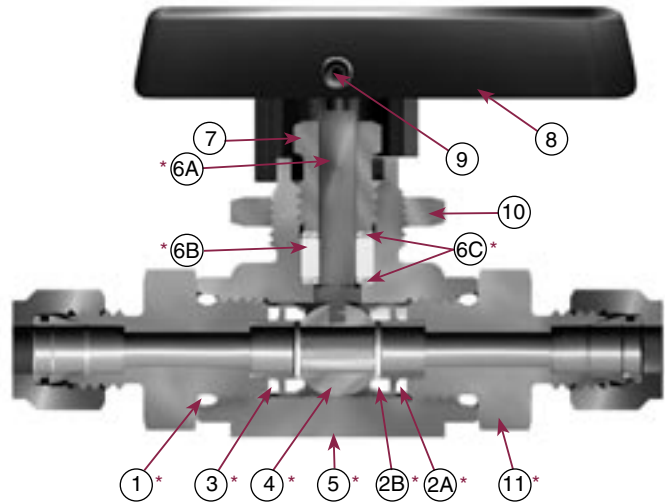

Model Shown: 6A-B6LJ-SSP

## Materials of Construction

Item #	Part Description	Stainless Steel	Brass
*1	Connector O-Ring	PTFE**	
*2A	Seat Retainer	ASTM A 276 Type 316	ASTM B 16 Alloy C36000
*2B	Seat	PTFE, PCTFE, PEEK	
*3	Retainer Seal	PTFE**	
*4	Ball	316 Stainless Steel	
*5	Body	ASTM A 351 Grade CF3M	ASTM B 283 Alloy C37700
*6A	Stem	ASTM A 276 Type 316	
*6B	Stem Seal	PTFE**	
*6C	Stem Washer	316 Stainless Steel	
7	Packing Nut	ASTM A 479 Type 316	ASTM B 453 Alloy C34000
8	Handle	Nylon 6/6	
9	Handle Set Screw	Stainless Steel	
10	Panel Nut	316 Stainless Steel	
*11	End Connector	ASTM A 479 Type 316	ASTM B 16 Alloy C36000

\* Wetted Parts.

\*\* Optional stem seal and body seal materials are described in the How to Order section.

Lubrication: Perfluorinated Polyether.

## Dimensions & Flow Data

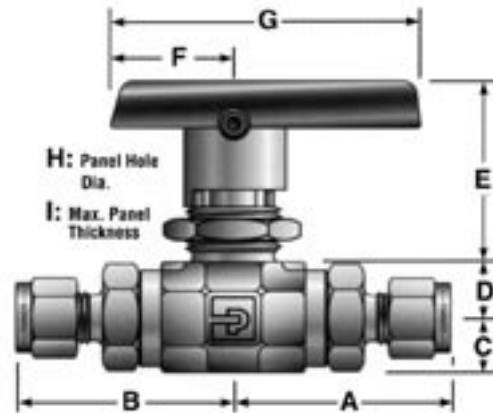

**Model Shown:  
4A-B6LJ-SSP**

Port Size	Basic Part #	Flow Data				End Connections				Dimensions Inches (mm)						
		Inch	mm	C <sub>v</sub>	X <sub>T</sub> *	Port 1	Port 2	A†	B†	C	D	E	F	G	H	I
1A	B2L	0.052	1.3	0.06	0.45	1/16" A-LOK®		1.30	1.30	0.33 (8.4)	0.33 (8.4)	0.94 (23.9)	0.75 (19.1)	1.88 (47.8)	0.58 (14.7)	0.13 (3.3)
1Z						1/16" CPI™		(33.0)	(33.0)							
2A		0.093	2.4	0.21	0.47	1/8" A-LOK®		1.36	1.36							
2Z						1/8" CPI™		(34.5)	(34.5)							
2F		0.165	4.2	0.93	0.43	1/8" Female NPT		1.07	1.07							
								(27.2)	(27.2)							
2M		0.165	4.2	0.93	0.43	1/8" Male NPT		1.18	1.18							
								(30.0)	(30.0)							
4A		0.165	4.2	0.93	0.43	1/4" A-LOK®		1.48	1.48							
4Z						1/4" CPI™		(37.6)	(37.6)							
4M	0.165	4.2	0.93	0.43	1/4" Male NPT		1.35	1.35								
							(34.3)	(34.3)								
4Q	0.165	4.2	0.93	0.43	1/4" UltraSeal		1.25	1.25								
							(31.8)	(31.8)								
4V	0.165	4.2	0.93	0.43	1/4" VacuSeal		1.38	1.38								
							(35.1)	(35.1)								
M3A	B6L	0.086	2.2	0.18	0.44	3mm A-LOK®		1.37	1.37	0.42 (10.7)	0.47 (11.9)	1.53 (38.9)	1.00 (25.4)	2.50 (63.5)	0.77 (19.6)	0.25 (6.4)
M3Z						3mm CPI™		(34.8)	(34.8)							
2A		0.093	2.4	0.26	0.46	1/8" A-LOK®		1.65	1.65							
2Z						1/8" CPI™		(41.9)	(41.9)							
4A		0.187	4.7	1.04	0.42	1/4" A-LOK®		1.74	1.74							
4Z						1/4" CPI™		(44.2)	(44.2)							
4F		0.250	6.4	2.34	0.29	1/4" Female NPT		1.51	1.51							
								(38.4)	(38.4)							
4M		0.250	6.4	2.34	0.29	1/4" Male NPT		1.62	1.62							
								(41.1)	(41.1)							
4Q	0.180	4.6	1.03	0.42	1/4" UltraSeal		1.51	1.51								
							(38.4)	(38.4)								
4V	0.188	4.8	1.04	0.42	1/4" VacuSeal		1.75	1.75								
							(44.5)	(44.5)								
6A	0.250	6.4	2.34	0.29	3/8" A-LOK®		1.80	1.80								
6Z					3/8" CPI™		(45.7)	(45.7)								
6M	0.250	6.4	2.34	0.29	3/8" Male NPT		1.62	1.62								
							(41.1)	(41.1)								
6Q	0.250	6.4	2.34	0.29	3/8" UltraSeal		1.51	1.51								
							(38.4)	(38.4)								
M6A	0.187	4.7	1.04	0.42	6mm A-LOK®		1.75	1.75								
M6Z					6mm CPI™		(44.5)	(44.5)								
M8A	0.250	6.4	2.34	0.42	8mm A-LOK®		1.78	1.78								
M8Z					8mm CPI™		(45.2)	(45.2)								
M10A	0.250	6.4	2.34	0.42	10mm A-LOK®		1.81	1.81								
M10Z					10mm CPI™		(46.0)	(46.0)								
6F	B8L	0.406	10.3	6.42	0.37	3/8" Female NPT		1.95	1.95	0.69 (17.5)	0.70 (17.8)	1.74 (44.2)	1.50 (38.1)	4.00 (101.6)	0.90 (22.9)	0.38 (9.7)
8F		0.406	10.3	6.42	0.37	1/2" Female NPT		2.15	2.15							
								(54.6)	(54.6)							
8A		0.406	10.3	6.42	0.37	1/2" A-LOK®		2.34	2.34							
8Z						1/2" CPI™		(59.4)	(59.4)							
8M		0.406	10.3	6.42	0.37	1/2" Male NPT		2.22	2.22							
								(56.4)	(56.4)							
8Q		0.375	9.5	5.57	0.37	1/2" UltraSeal		1.92	1.92							
								(48.8)	(48.8)							
8V		0.406	10.3	6.42	0.37	1/2" VacuSeal		2.21	2.21							
							(56.1)	(56.1)								
12A	B12L	0.406	10.3	6.42	0.37	3/4" A-LOK®		2.33	2.33	0.69 (17.5)	0.70 (17.8)	1.74 (44.2)	1.50 (38.1)	4.00 (101.6)	0.90 (22.9)	0.38 (9.7)
12Z						3/4" CPI™		(59.2)	(59.2)							
12F		0.406	10.3	6.42	0.37	3/4" Female NPT		2.25	2.25							
								(57.1)	(57.1)							
M12A		0.375	9.5	5.57	0.37	12mm A-LOK®		2.33	2.33							
M12Z						12mm CPI™		(59.2)	(59.2)							
M16A		0.406	10.3	6.42	0.37	16mm A-LOK®		2.33	2.33							
M16Z						16mm CPI™		(59.2)	(59.2)							

\* Tested in accordance with ISA S75.02. Gas flow will be choked when  $P_1 - P_2 / P_1 = X_T$

† For CPI™ and A-LOK®, dimensions are measured with nuts in the finger tight position

## Introduction

Parker manually, pneumatically, and electrically actuated three-way B Series Ball Valves may be used as diverting or selecting valves for fluids utilized in process and instrumentation applications. The standard three-way diverter valve is designed to accept media through the bottom port and direct it out of two outlet ports. When equipped with spring-loaded seats, the three-way valve may be used as a selector valve, alternately accepting media from either of two inlet sources (side ports) and directing it through a single outlet (bottom port).

## Features

- ▶ Available in 316 stainless steel and brass construction. Alloy N24135 and Alloy N30002 construction available for Diverter Valves upon request.
- ▶ Micro-finished ball provides a positive seal.
- ▶ Wide variety of US Customary and SI ports.
- ▶ 180 degree actuation.
- ▶ Panel mountable.
- ▶ Adjustable PTFE stem seal can be maintained in-line.
- ▶ Handle indicates flow direction.
- ▶ Low operating torques.
- ▶ Positive handle stops.
- ▶ Color coded handles.
- ▶ Optional pneumatic and electric actuation.
- ▶ Optional live-loaded PTFE stem seals.
- ▶ Optional non-adjustable O-ring stem seals.
- ▶ Optional stainless steel and extended handles.

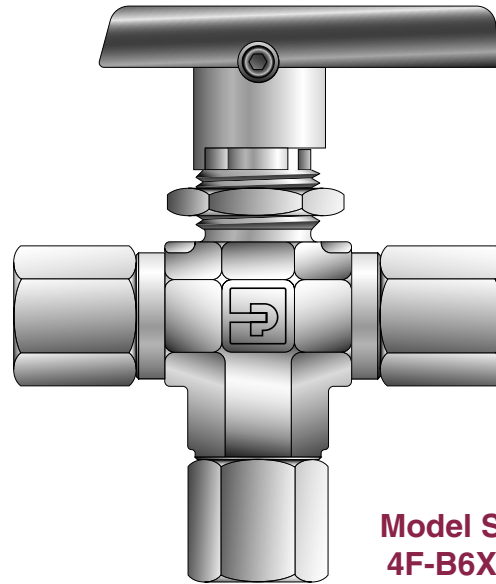

**Model Shown:  
4F-B6XJ2-BP**

## Diverter Valve Specifications

### Pressure Ratings with bottom port as inlet:

Material	CWP	with PTFE Seats
316 Stainless Steel	6000 psig (414 bar)*	1500 psig (103 bar)
Brass	3000 psig (207 bar)	1500 psig (103 bar)
Alloy N24135 (400)		
B2 and B6:	3000 psig (207 bar)	1500 psig (103 bar)
B8:	2000 psig (138 bar)	1500 psig (103 bar)
Alloy N30002 (C-276)		
B2 and B6:	4000 psig (276 bar)	1500 psig (103 bar)
B8:	3000 psig (207 bar)	1500 psig (103 bar)

\* B6 Series: 6000 psig rating or 4400 psig (303 bar) CWP  
B8 Series: 6000 psig rating or 4000 psig (276 bar) CWP

### Pressure Rating with side ports as inlet:

150 psig (10 bar)

## Selector Valve Specifications

(Spring Loaded – B6 and B8 models only)

### Pressure Rating with bottom port as inlet:

316 Stainless Steel ..... 6000 psig (414 bar) CWP\*  
Brass ..... 3000 psig (207 bar) CWP

### Pressure Rating with side ports as inlet:

316 Stainless Steel and Brass ..... 3000 psig (207 bar) CWP

### Pressure Rating and Tubing Selection

For working pressures of A-LOK® and CPI™ tube connections, please see the Instrument Tubing Selection Guide (Bulletin 4200-TS), found in the Technical Section of the Parker Instrumentation Process Control Binder, or the Parker Instrument Fitting Installation Manual (Bulletin 4200-B4).

For working pressures of valves with external or internal pipe threads, please see Catalog 4260, Instrumentation Pipe Fittings.

## Diverter Valve

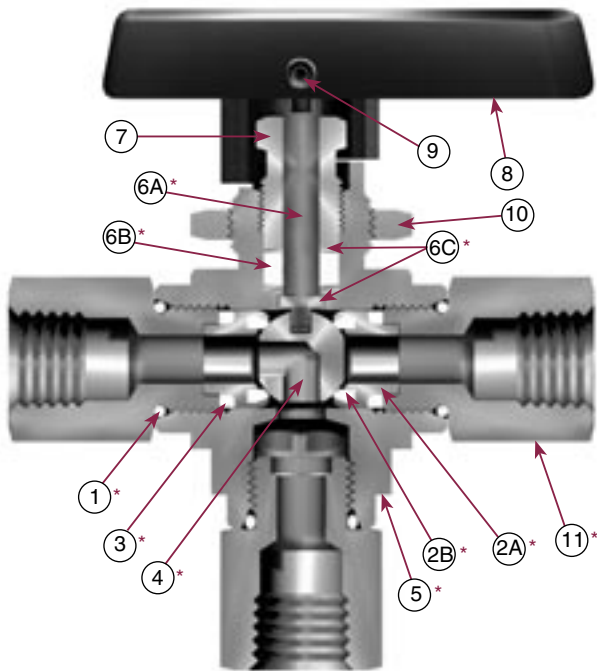

Model Shown: 4F-B6XJ-SSP

## Selector Valve

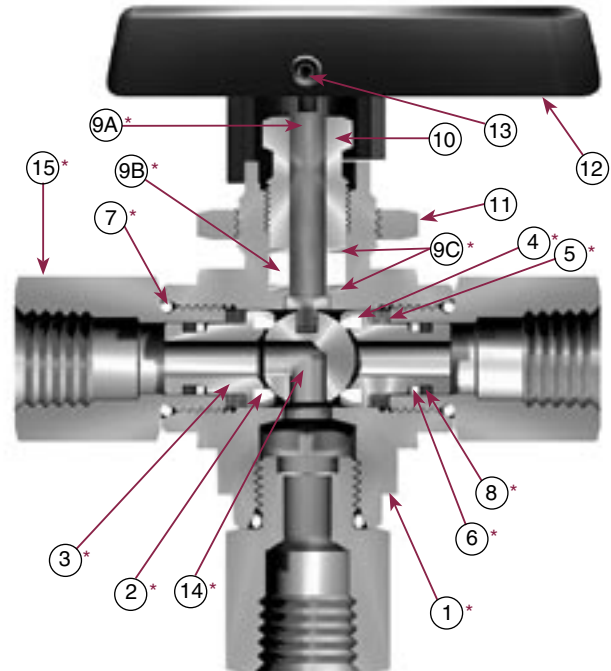

Model Shown: 4F-B6XS2-SSP

### Materials of Construction

Item #	Part Description	Stainless Steel	Brass
*1	Connector O-Ring	PTFE**	
*2A	Seat Retainer	ASTM A 276 Type 316	ASTM B 16 Alloy C36000
*2B	Seat	PTFE, PCTFE, PEEK	
*3	Retainer Seal	PTFE**	
*4	Ball	316 Stainless Steel	
*5	Body	ASTM A 351 Grade CF3M	ASTM B 283 Alloy C37700
*6A	Stem	ASTM A 276 Type 316	
*6B	Stem Seal	PTFE**	
*6C	Stem Washer	316 Stainless Steel	
7	Packing Nut	ASTM A 479 Type 316	ASTM B 453 Alloy C34000
8	Handle	Nylon 6/6	
9	Handle Set Screw	Stainless Steel	
10	Panel Nut	316 Stainless Steel	
*11	End Connector	ASTM A 479 Type 316	ASTM B 16 Alloy C36000

\* Wetted Parts.

\*\* Optional stem seal and body seal materials are described in the How to Order section.

Lubrication: Perfluorinated polyether.

### Materials of Construction

Item #	Part Description	Stainless Steel	Brass
*1	Body	ASTM A 351 Grade CF3M	ASTM B 283 Alloy C37700
*2	Seat	PTFE, PEEK	
*3	Seat Retainer	ASTM A 276 Type 316	
*4	Spring	Stainless Steel	
*5	Seat Retainer Washer	316 Stainless Steel	
*6	Back-up Ring	PTFE	
*7	Connector O-Ring	PTFE**	
*8	Seat Retainer O-Ring	Fluorocarbon Rubber**	
*9A	Stem	ASTM A 276 Type 316	
*9B	Stem Seal	PTFE*	
*9C	Stem Washer	316 Stainless Steel***	
10	Packing Nut	ASTM A 479 Type 316	ASTM B 453 Alloy C34000
11	Panel Nut	316 Stainless Steel	
12	Handle	Nylon 6/6	
13	Handle Set Screw	Stainless Steel	
*14	Ball	316 Stainless Steel	
*15	End Connector	ASTM A 479 Type 316	ASTM B 16 Alloy C36000

\* Wetted Parts.

\*\* Optional stem seal and body seal materials are described in the How to Order section.

Lubrication: Perfluorinated polyether.

\*\*\* The lower stem washer material is PEEK for B8 Selector Valves.

Lubrication: Perfluorinated polyether.

## Dimensions & Flow Data

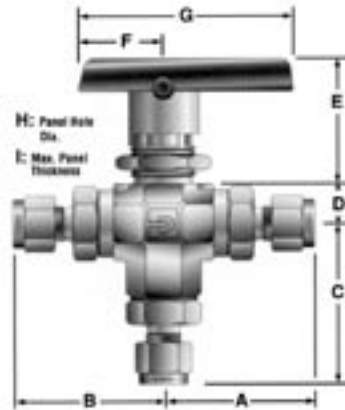

**Model Shown:**  
**4Z-B6XSPKR-V-SSP**

Port Size	Basic Part #	Flow Data				End Connections			Dimensions Inches (mm)															
		Inch	mm	$C_v$	$X_T^*$	Port 1	Port 2	Port 3	A†	B†	C	D	E	F	G	H	I							
1A	B2X	0.052	1.3	0.06	0.56	1/16" A-LOK®			1.30 (33.0)	1.30 (33.0)	1.39 (35.3)	0.33 (8.4)	0.94 (23.9)	0.75 (19.1)	1.88 (47.8)	0.58 (14.7)	0.13 (3.3)							
1Z						1/16" CPI™																		
2A		0.093	2.4	0.21	0.64	1/8" A-LOK®			1.36 (34.5)	1.36 (34.5)	1.45 (36.8)													
2Z						1/8" CPI™																		
2F		0.165	4.2	0.63	0.59	1/8" Female NPT			1.07 (27.2)	1.07 (27.2)	1.15 (29.2)													
2M		0.165	4.2	0.63	0.59	1/8" Male NPT			1.18 (30.0)	1.18 (30.0)	1.26 (32.0)													
4A		0.165	4.2	0.63	0.59	1/4" A-LOK®			1.48 (37.6)	1.48 (37.6)	1.56 (39.6)													
4Z						1/4" CPI™																		
4M		0.165	4.2	0.63	0.59	1/4" Male NPT			1.35 (34.3)	1.35 (34.3)	1.43 (36.3)													
4Q		0.165	4.2	0.63	0.59	1/4" UltraSeal			1.25 (31.8)	1.25 (31.8)	1.33 (33.8)													
4V		0.165	4.2	0.63	0.59	1/4" VacuSeal			1.38 (35.1)	1.38 (35.1)	1.46 (37.1)													
M3A		0.086	2.2	0.18	0.63	3mm A-LOK®			1.37 (34.8)	1.37 (34.8)	1.45 (36.8)													
M3Z						3mm CPI™																		
2A		B6X	0.093	2.4	0.21	0.38	1/8" A-LOK®			1.65 (41.9)	1.65 (41.9)							1.79 (45.5)	0.47 (11.9)	1.53 (38.9)	1.00 (25.4)	2.50 (63.5)	0.77 (19.6)	0.25 (6.4)
2Z							1/8" CPI™																	
4A			0.187	4.7	0.70	0.69	1/4" A-LOK®			1.74 (44.2)	1.74 (44.2)							1.88 (47.8)						
4Z						1/4" CPI™																		
4F	0.196		5.0	0.87	0.74	1/4" Female NPT			1.51 (38.4)	1.51 (38.4)	1.65 (41.9)													
4M	0.196		5.0	0.87	0.74	1/4" Male NPT			1.62 (41.1)	1.62 (41.1)	1.76 (44.7)													
4Q	0.180		4.6	0.68	0.67	1/4" UltraSeal			1.51 (31.8)	1.51 (31.8)	1.65 (33.8)													
4V	0.188		4.8	0.70	0.69	1/4" VacuSeal			1.75 (35.1)	1.75 (35.1)	1.89 (37.1)													
6A	0.196		5.0	0.87	0.74	3/8" A-LOK®			1.80 (45.7)	1.80 (45.7)	1.94 (49.3)													
6Z						3/8" CPI™																		
6M	0.196		5.0	0.87	0.74	3/8" Male NPT			1.62 (41.1)	1.62 (41.1)	1.76 (44.7)													
6Q	0.196		5.0	0.87	0.74	3/8" UltraSeal			1.52 (38.6)	1.52 (38.6)	1.65 (41.9)													
M6A	0.187		4.7	0.70	0.69	6mm A-LOK®			1.75 (44.5)	1.75 (44.5)	1.88 (47.8)													
M6Z						6mm CPI™																		
M8A	0.196		5.0	0.87	0.74	8mm A-LOK®			1.78 (45.2)	1.78 (45.2)	1.91 (48.5)													
M8Z						8mm CPI™																		
M10A	0.196	5.0	0.87	0.74	10mm A-LOK®			1.81 (46.0)	1.81 (46.0)	1.95 (49.5)														
M10Z					10mm CPI™																			
6F	B8X	0.406	10.3	3.62	0.64	3/8" Female NPT			1.95 (49.5)	1.95 (49.5)	2.29 (58.2)	0.70 (17.8)	1.74 (44.2)	1.50 (38.1)	4.00 (101.6)	0.90 (22.9)	0.38 (9.7)							
8A		0.406	10.3	3.62	0.64	1/2" A-LOK®			2.34 (59.4)	2.34 (59.4)	2.68 (68.1)													
8Z						1/2" CPI™																		
8F		0.406	10.3	3.62	0.64	1/2" Female NPT			2.15 (54.6)	2.15 (54.6)	2.49 (63.2)													
8M		0.406	10.3	3.62	0.64	1/2" Male NPT			2.22 (56.4)	2.22 (56.4)	2.59 (65.8)													
8Q		0.375	9.5	3.46	0.62	1/2" UltraSeal			1.93 (49.5)	1.93 (49.5)	2.27 (57.7)													
8V		0.406	10.3	3.62	0.64	1/2" VacuSeal			2.21 (56.1)	2.21 (56.1)	2.55 (65.0)													
12A		0.406	10.3	3.62	0.64	3/4" A-LOK®			2.33 (59.2)	2.33 (59.2)	2.68 (68.1)													
12Z						3/4" CPI™																		
12F		0.406	10.3	6.42	0.37	3/4" Female NPT			2.25 (57.1)	2.25 (57.1)	2.59 (65.8)													
M12A		0.375	9.5	3.46	0.62	12mm A-LOK®			2.33 (59.2)	2.33 (59.2)	2.67 (67.8)													
M12Z						12mm CPI™																		
M16A		0.406	10.3	3.62	0.64	16mm A-LOK®			2.33 (56.9)	2.33 (56.9)	2.67 (65.5)													
M16Z						16mm CPI™																		

\* Tested in accordance with ISA S75.02. Gas flow will be choked when  $P_1 - P_2 / P_1 = X_T$

† For CPI™ and A-LOK®, dimensions are measured with nuts in the finger tight position

## How to Order

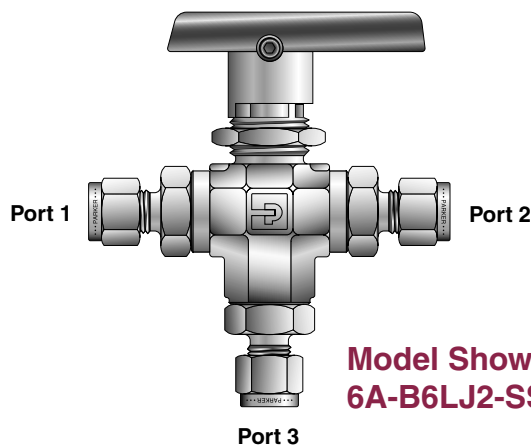
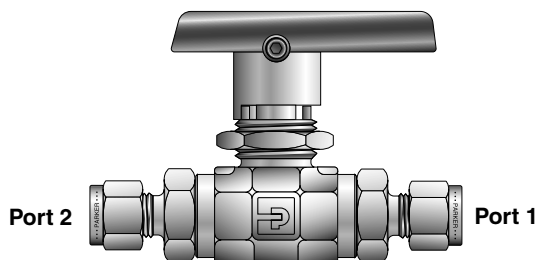

**Model Shown: 6A-B6XJ2-SSP**

**Model Shown: 6A-B6LJ2-SSP**

Port 1	Port 2	Port 3	Valve Series	Seat Material	Seal Material	Body Material
1A	1/16" A-LOK®		B2L	J PTFE	(Blank) PTFE	SSP 316 Stainless Steel
1Z	1/16" CPI™		B2X	J2 PCTFE	V Fluorocarbon Rubber	BP Brass
2A	1/8" A-LOK®				EPR Ethylene Propylene Rubber	MP Alloy N24135
2Z	1/8" CPI™				BN Nitrile Rubber	HCP Alloy N30002
2F	1/8" Female NPT				KZ Highly Fluorinated Fluorocarbon Rubber	
2M	1/8" Male NPT				LT Live-Loaded PTFE Packing with PTFE Seals	
4A	1/4" A-LOK®				VLT Live-Loaded PTFE Packing with Fluorocarbon Rubber Seals	
4Z	1/4" CPI™				EPRLT Live-Loaded PTFE Packing with Ethylene Propylene Rubber Seals	
4M	1/4" Male NPT				BNLT Live-Loaded PTFE Packing with Nitrile Rubber Seals	
4Q	1/4" UltraSeal				KZLT Live-Loaded PTFE Packing with Highly Fluorinated Fluorocarbon Rubber Seals	
4V	1/4" VacuSeal					
M3A	3mm A-LOK					
M3Z	3mm CPI™					
2A	1/8" A-LOK®		B6L	J PTFE		
2Z	1/8" CPI™		B6X	J2 PCTFE		
4A	1/4" A-LOK®			S2 Spring-Loaded PCTFE		
4Z	1/4" CPI™			PKR PTFE Lubricated PEEK		
4F	1/4" Female NPT			SPKR Spring-Loaded PTFE Lubricated PEEK		
4M	1/4" Male NPT					
4Q	1/4" UltraSeal					
4V	1/4" VacuSeal					
6A	3/8" A-LOK®					
6Z	3/8" CPI™					
6M	3/8" Male NPT					
6Q	3/8" UltraSeal					
M6A	6mm A-LOK®					
M6Z	6mm CPI™					
M8A	8mm A-LOK®					
M8Z	8mm CPI™					
M10A	10mm A-LOK®					
M10Z	10mm CPI™					
6F	3/8" Female NPT		B8L	J PTFE		
8A	1/2" A-LOK®		B8X	J2 PCTFE		
8Z	1/2" CPI™			S2 Spring-Loaded PCTFE		
8F	1/2" Female NPT			PKR PTFE Lubricated PEEK		
8M	1/2" Male NPT					
8Q	1/2" UltraSeal					
8V	1/2" VacuSeal					
12A	3/4" A-LOK®					
12Z	3/4" CPI™					
12F	3/4" Female NPT					
M12A	12mm A-LOK®					
M12Z	12mm CPI™					
M16A	16mm A-LOK®					
M16Z	16mm CPI™					

**Notes:** 1. Panel Mounting Nut supplied with each valve. Various port combinations are available.  
 2. See How to Order.  
 3. VacuSeal and UltraSeal are not available in Brass.  
 4. 12F (3/4" Female NPT) not panel mountable.

See examples on page 9. See pages 10 and 11 for information about How to Order Options and Maintenance Kits.

## How to Order (Continued)

### Examples: Two-Way Valves

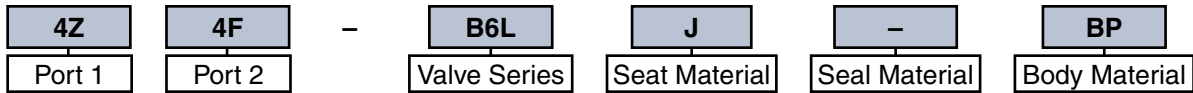

Describes a B6L ball valve with a 1/4" CPI™ end connection for port 1 and a 1/4" female NPT end connection for port 2, PTFE seats, PTFE stem and body seals, brass construction, with a panel mounting nut.



Describes a B8L ball valve with a 1/2" A-LOK® end connections for ports 1 and 2, PTFE seats, Nitrile rubber stem and body seals, stainless steel construction, with a panel mounting nut.

**\*Note:** If ports 1 and 2 are the same, eliminate the port 2 designator.

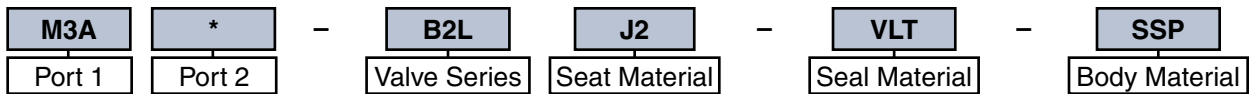

Describes a B2L ball valve with 3mm A-LOK® end connections for ports 1 and 2, PCTFE seats, fluorocarbon rubber body seals, live-loaded PTFE packing, stainless steel construction, with a panel mounting nut. **\*Note:** If ports 1 and 2 are the same, eliminate the port 2 designator.

### Examples: Three-Way Diverter Valves

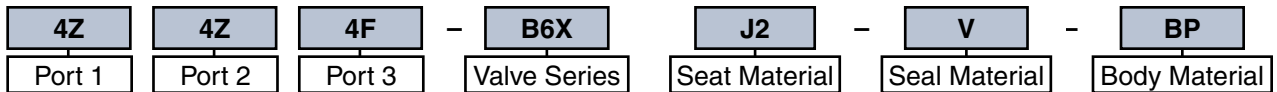

Describes a B6X ball valve with 1/4" CPI™ end connections for side ports 1 and 2, 1/4" female NPT end connection for bottom port 3, PCTFE seats, fluorocarbon rubber stem and body seals, brass construction, and a panel mounting nut.

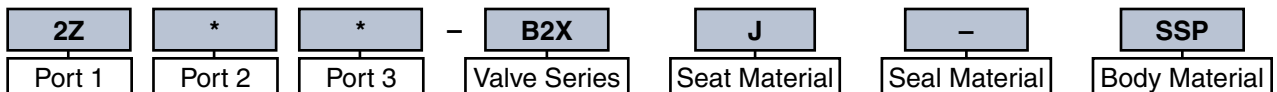

Describes a B2X ball valve with 1/8" CPI™ end connections for ports 1, 2, and 3, PTFE seats, PTFE stem and body seals, stainless steel construction, and a panel mounting nut.

**\*Note:** If ports 1, 2, and 3 are the same, eliminate the port 2 and port 3 designators.

### Examples: Three-Way Selector Valves

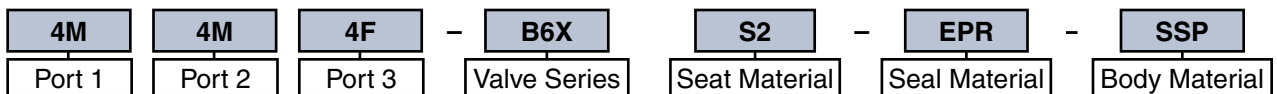

Describes a B6X ball valve with 1/4" male NPT end connections for side ports 1 and 2, 1/4" female NPT end connection for bottom port 3, spring-loaded PCTFE seats, ethylene propylene rubber stem and body seals, stainless steel construction, and a panel mounting nut.

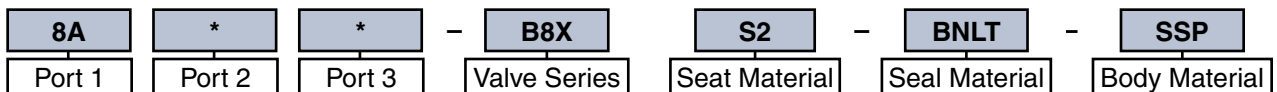

Describes a B8X ball valve with 1/2" A-LOK® end connections for ports 1, 2, and 3, spring-loaded PCTFE seats, Nitrile rubber body seals, live loaded PTFE packing, stainless steel construction, and a panel mounting nut.

**\*Note:** If ports 1, 2, and 3 are the same, eliminate the port 2 and port 3 designators.

## Options

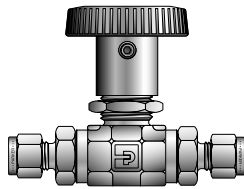

Round Handle

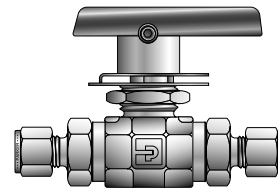

Lock-Out Handle

## Actuator Options

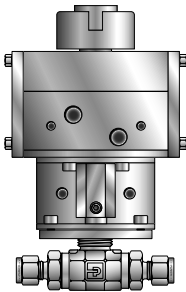

Double Acting (61AD)  
Pneumatic Actuator



Spring Returns (61AC & AO)  
Pneumatic Actuator



70 and 80 Series  
Electric Actuator



O-Ring Stem Seals



Live-Loaded Stem Seals

## Two-Way Valve Upstream and Downstream Drain Options

For draining upstream or downstream media on two-way valves at pressures below 150 psig (10 bar), add the suffix **-VBU** (Vented Ball Upstream) or **-VBD** (Vented Ball Downstream). Example: 4Z-B6LJ-SSP-VBU. This option is also suitable to vent the ball cavity in vacuum applications. For pressures up to 3,000 psig (207 bar), select **S2** or **SPKR** spring-loaded seats and add the suffix **-VBU** (Vented Ball Upstream) or **-VBD** (Vented Ball Downstream). Example: 4Z-B6LS2-SSP-VBU

**Note:** VBD and BVU are ball cavity vents only.

## How to Order Options

	<b>Examples</b>
<b>Lock-Out Devices:</b> Add the suffix LD to the end of the part number to order directly on the valve. For field installation, simply substitute the correct valve series number after LD.	4F-B6LJ2-BN-SSP-LD <b>LD-B8L</b>
<b>Colored Lever Handles:</b> Add the designator corresponding to the correct handle as a suffix to the part number (black is standard). <b>W</b> = white, <b>B</b> = blue, <b>G</b> = green, <b>R</b> = red, <b>Y</b> = yellow.	M6A-B6XPKR-SSP-G
<b>Colored Round Handles:</b> Add the designator corresponding to the correct handle as a suffix to the part number. <b>S</b> = Black, <b>S-W</b> = white, <b>S-B</b> = blue, <b>S-G</b> = green, <b>S-R</b> = red, <b>S-Y</b> = yellow. <b>NOTE:</b> Round handles are not recommended for B8 valves with PEEK seats.	M6A-B6XPKR-SSP-S-G
<b>Metal Oval Handles:</b> Add the designator corresponding to the correct handle as a suffix to the valve part number. <b>OVSS</b> = stainless steel, <b>OVAL</b> = aluminum.	8F-B8LPKR-SSP-OVSS
<b>Stainless Steel Handles:</b> Add the suffix <b>-ST</b> to the end of the part number.	4F-B6LJ-SSP-ST
<b>Pneumatic Actuators:</b> For detailed actuator information, refer to Catalog 4123-PA. For factory assembly, add the actuator part number as the suffix to the valve part number. For field installation, specify the actuator desired. The appropriate mounting hardware may be obtained by adding the valve series and actuator size to the prefix <b>MK-</b> .	2F-B2XJ2-V-SSP-61ACX-2 <b>61ACX-2</b> <b>MK-B2X-61</b>
<b>Electric Actuators:</b> For detailed actuator information refer to Catalog 4123-EA. For factory assembly, add the actuator part number as the suffix to the valve part number. For field installation, specify the actuator desired. The appropriate mounting hardware may be obtained by adding the valve series and actuator series to the prefix <b>MK-</b> .	8A-B8LPKR-BN-SS-71A <b>71A</b> <b>MK-B8L-70</b>
<b>Oxygen Cleaning:</b> Add the suffix <b>-C3</b> to the end of the part number to receive valves cleaned and assembled for oxygen service in accordance with Parker Specification ES8003.	4A-B6LJ-EPR-SSP-C3
<b>Electron Beam Welded End Connections:</b> For tamper resistant valves, add the suffix <b>-EBW</b> to the end of the part number of stainless steel valves to have end connections electron beam welded.	M6A-B6LSPKR-V-SSP-EBW
<b>H2S Environment:</b> To obtain valves suitable for H2S containing environments in accordance with NACE Standard MR0175/ISO 15156, add the suffix <b>-NC</b> to the end of the part number.	8F-B8LJ-BN-SSP-NC
<b>Grounding Spring:</b> To obtain B8 series valves with a grounding spring, add the suffix <b>-SPG</b> to the end of the part number.	8A-B8LJ2-SSP-SPG

## How to Order Maintenance Kits

<b>Colored Round Handle Kits:</b> Series-Handle-Color. (Example consists of a green handle and handle screw.)	<b>B6-RD-HANDLE-GREEN</b>
<b>Stainless Steel Handle Kits:</b> Series-Handle-SS. (Example consists of a stainless steel handle and handle screw.)	<b>B8-HANDLE-SS</b>
<b>Colored Lever Handle Kits:</b> Series-Handle-Color. (Example consists of a red handle and handle screw.)	<b>B6-HANDLE-RED</b>

### Two-way Valve Seal Kits:

<b>PTFE Stem Seal Kits:</b> Kit-Valve Series and Seat Material-Body Material. (Consists of one PTFE stem seal, two stem seal washers, two encapsulated PTFE ball seats, two end connector PTFE seals, one assembly mandrel, maintenance instructions.)	<b>KIT-B2LJ-SS</b>
<b>Elastomeric Stem Seal Kits:</b> Kit-Valve Series and Seat Material-Elastomer Material-Body Material. (Consists of two stem seal Nitrile rubber O-rings, two PTFE back-up rings, two stem seal washers, two encapsulated PCTFE ball seats, two end connector Nitrile rubber O-ring seals, two seat retainer Nitrile rubber O-ring seals, stem glands and maintenance instructions.)	<b>KIT-B2LJ2-BN-SS</b>

### Diverter Valve Seal Kits:

<b>PTFE Stem Seal Kits:</b> Kit-Valve Series and Seat Material-Body Material. (Consists of one PTFE stem seal, two stem seal washers, two encapsulated PEEK ball seats, three end connector PTFE seals, one assembly mandrel, maintenance instructions.)	<b>KIT-B6XPKR-SS</b>
<b>Elastomeric Stem Seal Kits:</b> Kit-Valve Series and Seat Material-Elastomer-Body Material. (Consists of two stem seal fluorocarbon rubber O-rings, two PTFE back-up rings, two stem seal washers, two encapsulated PTFE ball seats, three end connector fluorocarbon rubber O-ring seals, two seat retainer fluorocarbon rubber O-ring seals, stem glands and maintenance instructions.)	<b>KIT-B6XJ-V-SS</b>

### Selector Valve Seal Kits:

<b>PTFE Stem Seal Kits:</b> Kit-Valve Series and Seat Material. (Consists of one PTFE stem seal, two stem seal washers, two encapsulated spring-loaded PCTFE ball seats, two seat retainer fluorocarbon rubber O-rings, three end connector PTFE seals, one assembly mandrel, maintenance instructions.)	<b>KIT-B6XS2</b>
<b>Elastomeric Stem Seal Kits:</b> Kit-Valve Series and Seat Material-Elastomer. (Consists of two stem seal fluorocarbon rubber O-rings, two PTFE back-up rings, two stem seal washers, two encapsulated spring-loaded PEEK ball seat assemblies, three end connector fluorocarbon O-ring seals, two seat retainer fluorocarbon rubber O-rings, stem glands and maintenance instructions.)	<b>KIT-B6XSPKR-V</b>

### Live-loaded Seal Kits:

Kit-Valve Series and Seat Material-Seal Material-Body Material. (Consists of one live-loaded PTFE stem packing, two packing springs (B8 series valves have four springs), three packing washers, two PCTFE encapsulated ball seats, two Buna-N rubber end connector O-ring seals, two Nitrile rubber seat retainer O-ring seals, maintenance instructions.)	<b>KIT-B6LJ2-BNLT-SS</b>
--	--------------------------



**Parker Hannifin Corporation**

Instrumentation Products Division  
2651 Alabama Highway 21 North  
Jacksonville, AL 36265-9681  
USA

Phone: (256) 435-2130

Fax: (256) 435-7718

[www.parker.com/ipdus](http://www.parker.com/ipdus)

**Parker Hannifin plc**

Instrumentation Products Division  
Riverside Road  
Pottington Business Park  
Barnstaple, Devon EX31 1NP  
England

Phone: +44 (0) 1271 313131

Fax: +44 (0) 1271 373636

Email: [ipd@parker.com](mailto:ipd@parker.com)

[www.parker.com/ipd](http://www.parker.com/ipd)